

Operation Manual

Rotary Die Cutter

UD-310

- All rights reserved.
- Information in this documents is subject to change without notice.
- The external appearance may differ from the illustration depending on the manufacturing lot.
- Be sure NOT convert this machine.

Introduction

Thank you very much for purchasing our product.

Please carefully read this User Manual before using the product.

Be sure to read Chapter 1 "Safe and Proper use of Equipment" before use.

Keep this User's Manual in a location where it can be referred to at any time.

-
- All rights reserved.
 - Information in this document is subject to change without notice.
 - The external appearance may differ from the illustration depending on the manufacturing lot.
 - If you have any questions, contact your sales representative.
-

Important affair (Basic Handling)

The relationship between the printed paper (work design) and the die plate is very important on this product.

The work design and the die plate should be center position.

These condition is based, so the adjustable range of the Positioning Conveyer is within 3 mm.

(If you need to adjust more than 3 mm, please adjust by the die position on the magnet cylinder.)

The skew adjustable range is plus-minus 0.2 degree.

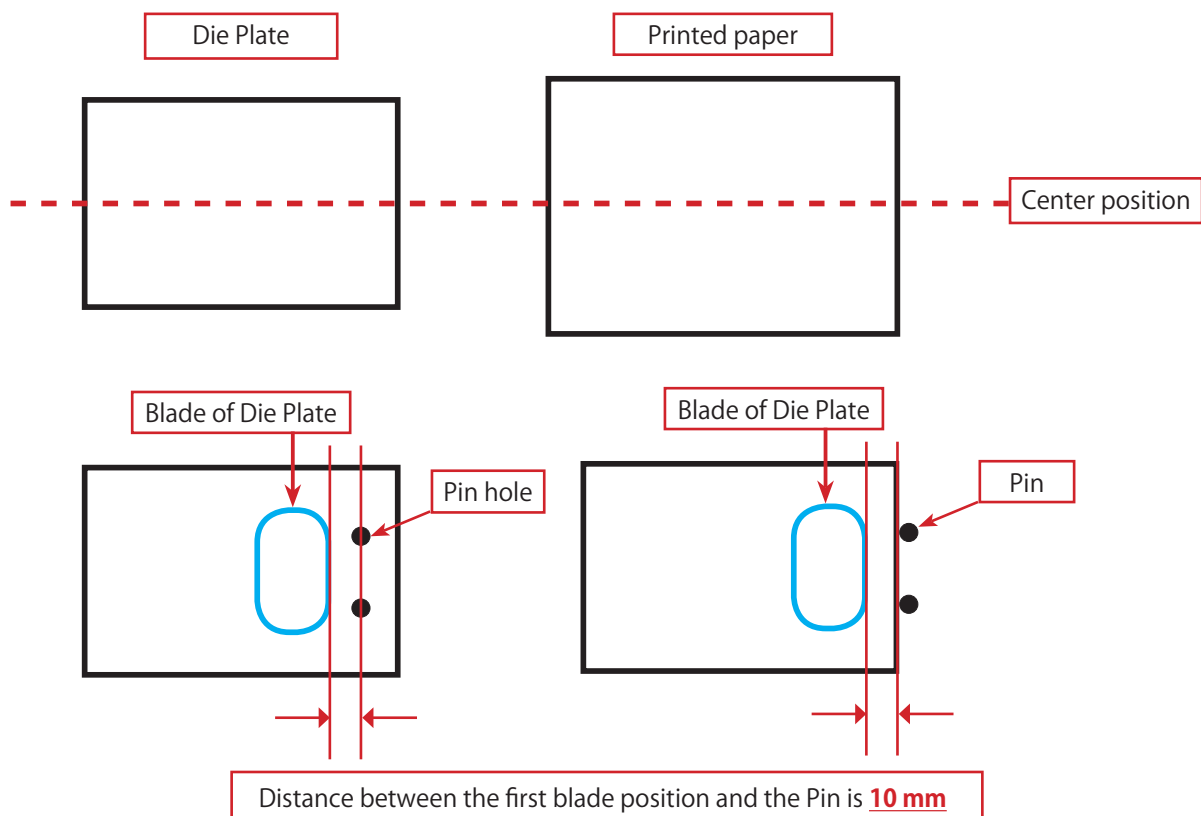

Position of Inter Lock switches (Be sure to read this) for Japan and North of America

* The following is for only Japan and North of America

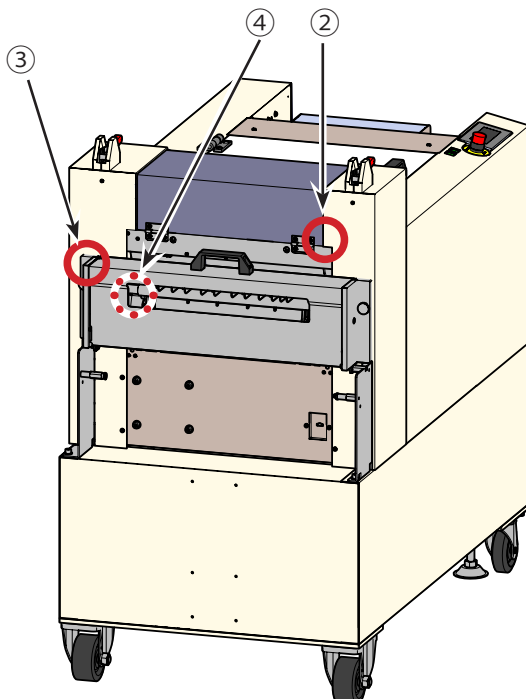
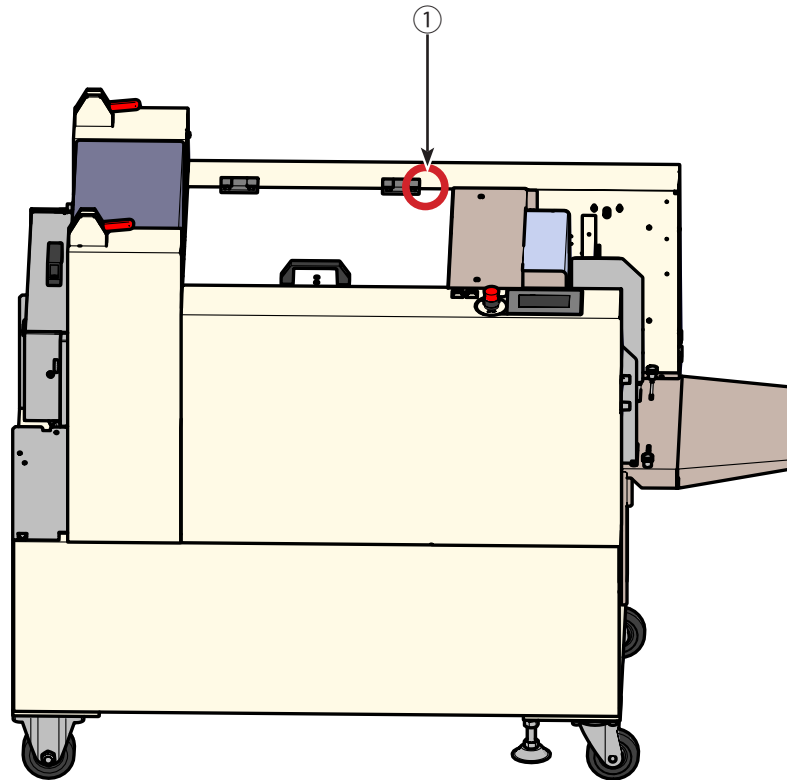

①	Positioning Conveyer Cover	The machine doesn't work while this cover opens.
②	Cylinder Cover	The machine doesn't work while this cover opens. * The cylinder moves a little right after open this cover because of the brake released. Please wait for 1 second and work.
③	Separator Cover	The machine doesn't work while this cover opens.
④	Separator Body	The machine doesn't work while this whole separator unit opens.

Position of Inter Lock switches (Be sure to read this)

for CE

* The following is only for CE

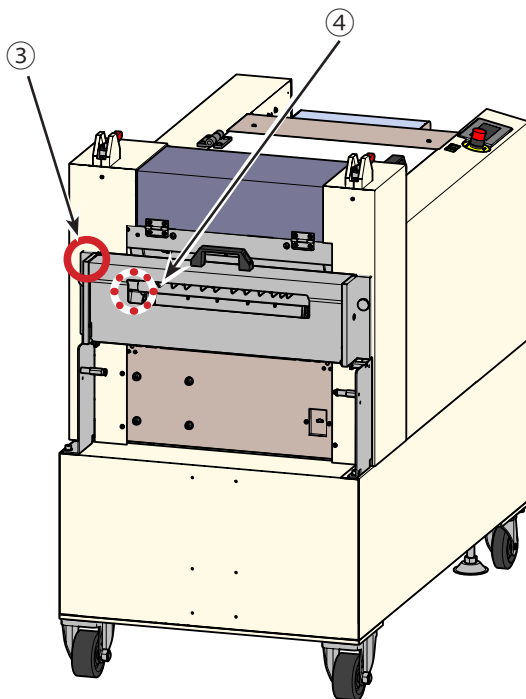
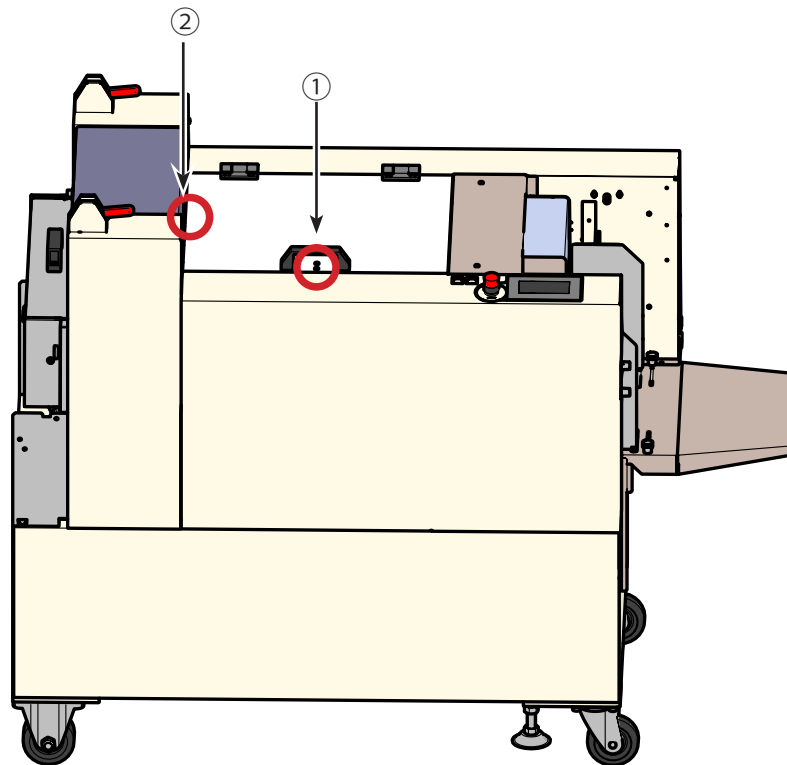

①	Positioning Conveyer Cover	The machine doesn't work while this cover opens.
②	Cylinder Cover	The machine doesn't work while this cover opens. * The cylinder moves a little right after open this cover because of the brake released. Please wait for 1 second and work.
③	Separator Cover	The machine doesn't work while this cover opens.
④	Separator Body	The machine doesn't work while this whole separator unit opens.



Contents

1. Safe and Proper Use of Equipment (Be sure to observe each item)	6
1-1 Explanation of Warnings (Signal Word)	6
1-2 Explanation of Warning Labels Attachment Locations.....	7
1-3 Note for Safe Use	9
1-4 Disposal of Old Electrical & Equipment.....	10
2. Preparation.....	11
2-1 Accessories.....	11
2-2 Unit Assembly.....	12
3. Name of Parts.....	15
3-1 Air Feeder Unit.....	15
When operate as XY registration function.....	17
3-2 Positioning Conveyer Unit	18
3-3 Magnetic Cylinder Unit	21
3-4 Separator Unit.....	23
4. Operation Process.....	24
4-1 Loading of Paper.....	24
(1) Paper Set.....	24
(2) Adjust the air volume and the double feeding prevention	25
(3) Adjust the Detection Bar (paper height)	26
4-2 Reading Sensor Switch and Registration Mark.....	27
(1) Read only Y axis registration mark.....	27
(2) Read X and Y axis registration mark	29
4-3 Die Plate Setting	31
4-4 Separator Setting	33
4-5 Touch Panel Setting	39
4-6 Fine Adjustment Setting	45
(1) Skew Adjustment.....	45
(2) Forward and Backward direction Adjustment	46
(3) Operation and Non-operation direction Adjustment.....	47
4-7 Skill for better process	48
(1) Use "Micro-joint" for difficult handling paper	48
(2) Use "Fluorine separate spray" for better separation from the Die Plate ..	49
(3) Use "Sponge" for better separation from the Die Plate.....	49
(4) Use "Sponge" or "Dammy Blades" for slipping problem	50
5. Aftercare.....	53
6. Troubleshooting	54
7. Specification.....	58

1. Safe and Proper Use of Equipment (Be sure to observe each item)

1-1 | Explanation of Warnings (Signal Word)

- The signal word is a warning indication which shows a message on the basic safe behaviour, classified by the level of impact (Injury) on a human body.
- The warning indication is classified by the level of danger by signal words of "Danger", "Warning", and "Caution".
- The warning indications are an important part of safety. If the equipment is mishandled, serious accidents may occur resulting in death or serious injury, or damage to the equipment. Be sure to observe the contents indicated in this manual and the warning labels.
- The signal word, types of danger, level of danger and avoidance of danger are indicated in the warning labels.
- Be sure to read the warning indications indicated in this manual and in the warning labels, and sufficiently understand the contents before starting work.

 DANGER	Danger indicates an imminently hazardous situation that, if not avoided, will result in death or serious injury.
 WARNING	Warning indicates a potentially hazardous situation that, if not avoided, may result in death or serious injury.
 CAUTION	Caution indicates a potentially hazardous situation that, if not avoided, may result in minor or moderate injury. Caution is also used to indicate a potentially hazardous situation, where property damage only can be expected.

■ Examples of Warning Label Indications

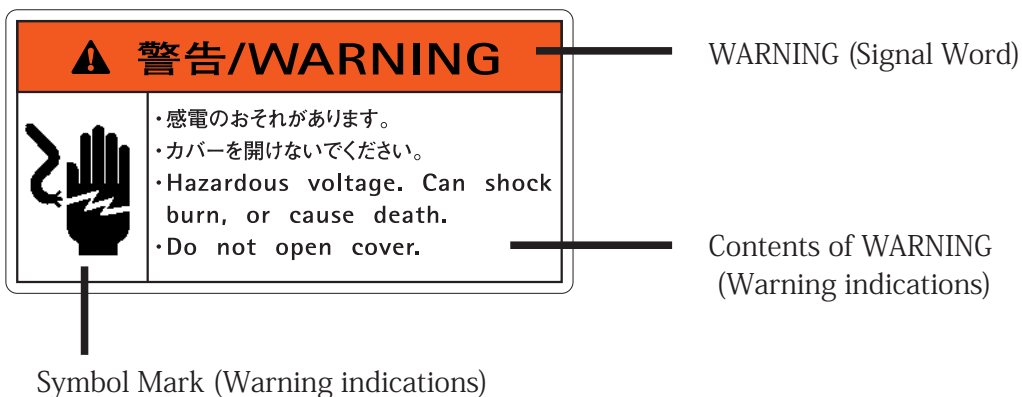

1-2 | Explanation of Warning Labels Attachment Locations

The locations, type and part number of the warning labels attached to the equipment are as follows.

- Observe the contents of the Warning label, and perform safe work avoiding accidents.
- DO NOT remove the Warning labels.
- If the Warning label can not be read or has been removed, contact your sales representative for a new label.
- The external appearance may differ from the illustration depending on the manufacturing lot; however, the attachment location of the Warning labels is the same.

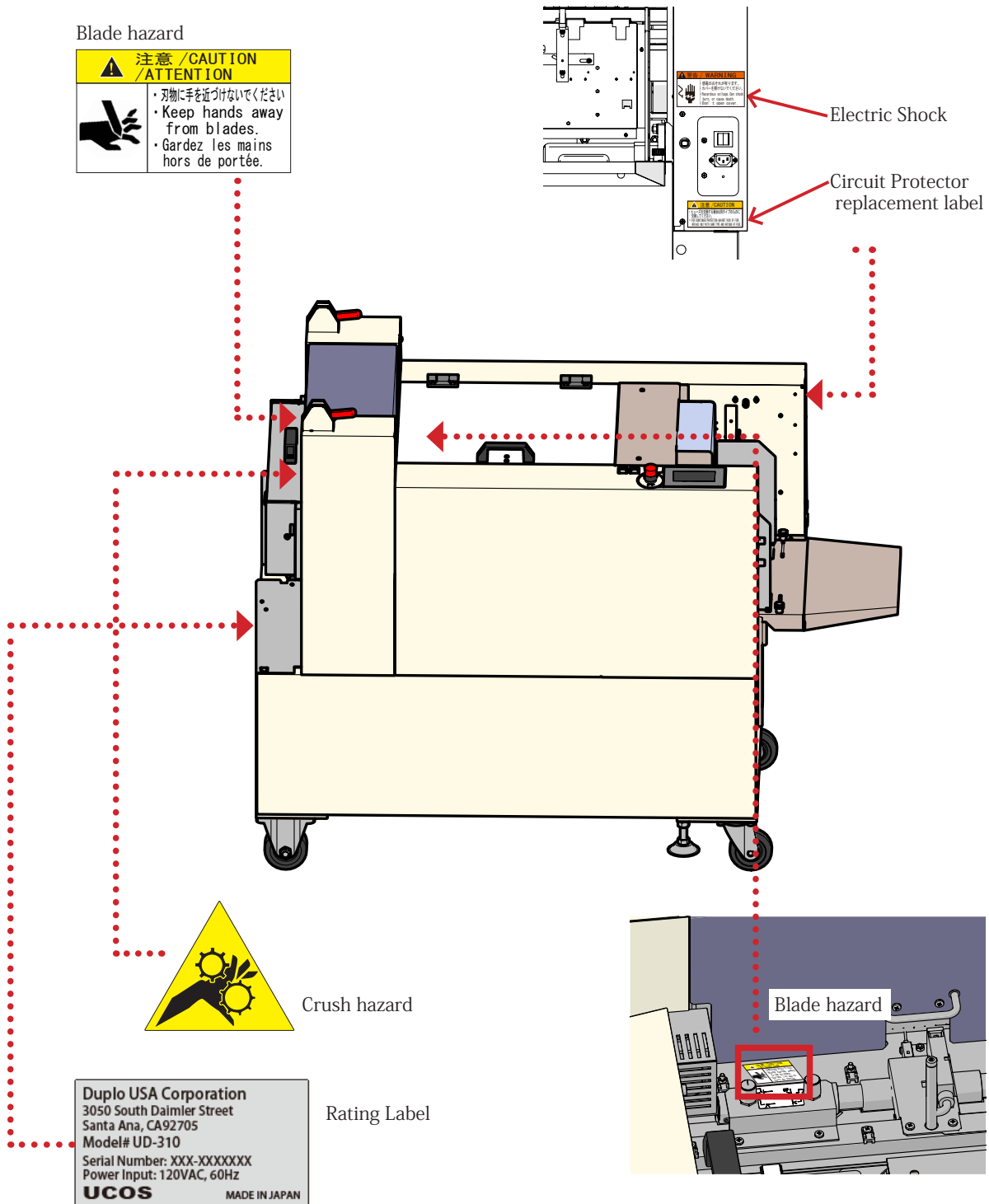

● General Notes



WARNING

- Do not modify the equipment, remove components, or attach components not specified by our company without permission.
There is a possibility of injury, or damage to the equipment. We will not guarantee the quality of the equipment if any of the above items are performed.
- Do not remove the safety devices intentionally, or deactivate the functions to use the equipment.
There is a possibility of the human body being exposed to danger, or damage of the equipment caused by a malfunction.



CAUTION

- Immediately stop the use of the equipment if smoke comes out of the equipment, or equipment becomes abnormally hot during operation.
Contact your sales representative after removing the power cable from the outlet.

● Notes regarding Electrical Shock



WARNING

- There is a possibility of receiving an electrical shock, if the cover is removed while the power cable of the equipment is plugged in.
There is a possibility of a major accident occurring from an electrical shock, resulting in death or serious injury, or damage of the equipment.
- Do not remove unspecified covers.
- When connecting an additional ground wire, please request an electrical specialist.



● Release the Emergency Stop Button

- Emergency Stop Button spec: Use this button when the exceeding thing is happened.
Turn this button as the red arrow direction, and release it.

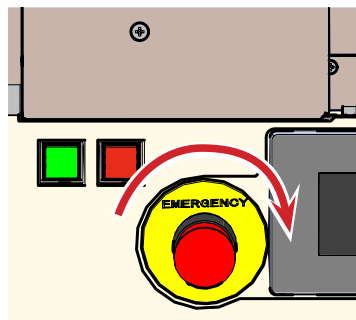

● Other Notes

- Make sure to use the ground earth cord, and make a ground connection.
- Do not place a flower vase or glass containing water on the equipment.
If water should enter into the equipment, it may cause failure. Do not place heavy items on the equipment.
- There are some air holes in the equipment covers.
The purpose of these air holes is to allow air to flow in and out of the equipment.
Do not place items near the air holes, or paper that will block the air holes.
- If a strong impact is given to the equipment, there is possibility of having an adverse effect.
Do not give a strong impact to the equipment at any time while working.
- Do not use any voltages other than the specified power supply voltage. Do not plug the equipment into outlets which have multiple plugs in use.
This may cause a fire or an electrical shock.
- Avoid the use of extension cords.
- Do not cut, damage, bundle, or modify the power cord.
Do not place heavy items on the power cord, pull or sharply bend, as it may cause a fire or electrical shock.
- If metal or etc. contacts the prongs of the power plug, it may cause a fire or electrical shock.
- Install the equipment in a position as close to the power receptacle as possible, so that the power plug can be easily removed when any abnormality occurs.
- If there is damage to the power cord, exposure or wire breakage of the core wire is found, contact a service contractor to replace the power cord.
- If a foreign substance, such as metal, water or other liquids accidentally get into the equipment, disconnect the power cord from the outlet, and contact a service contractor.
If the power cord is used as it is, it may cause a fire or an electrical shock.
- When moving the equipment, be sure to disconnect the power cord from the outlet before moving. If not, the cord will be damaged and may cause a fire or an electrical shock.
- Be sure to disconnect the power plug from the outlet for safety before performing any service.
- Be sure to grab the plug when disconnecting the power plug.
Do not pull on the power cord. The cord will be damaged, and may cause a fire or an electrical shock.
- Do not use the accessories (power cable, etc.) included with this equipment, for other products.

● Install space

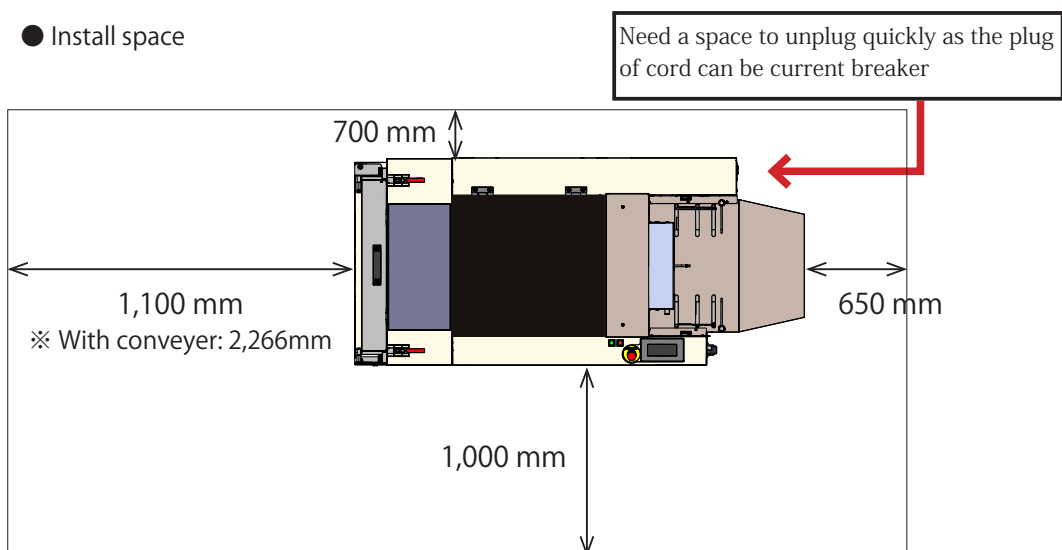



Disposal of Old Electrical & Electronic Equipment

This symbol (the symbol of the crossed out wheeled bin) indicates that in European countries this product should not be disposed of as household waste.

Please recycle where facilities exist by checking with your local authority or supplier for recycling advice.

By ensuring this product is disposed of correctly through proper treatment, recovery and recycling, you will help prevent potential negative effects on the environment and human health.

En



Entsorgung von alten elektrischen und elektronischen Ausrüstungsteilen

Dieses Symbol (das Symbol mit dem durchgekreuzten fahrbaren Müllbehälter) zeigt an, dass dieses Produkt in europäischen Ländern nicht als Haushaltsmüll entsorgt werden darf. Bitte informieren Sie sich bei Ihren örtlichen Behörden oder bei Ihrem Händler hinsichtlich einer Empfehlung für die Entsorgung und führen Sie die betreffenden Teile dort, wo solche Einrichtungen vorhanden sind, einem Recycling-Prozess zu.

Indem sie sicherstellen, dass das betreffende Produkt durch richtige Behandlung, Rückführung und Recycling entsorgt wird, tragen Sie dazu bei, möglichen negativen Auswirkungen auf die Umwelt und die menschliche Gesundheit vorzubeugen.

Ge



Élimination du matériel électronique et électrique usagé

Ce symbole (une poubelle marquée d'une croix) indique que dans les pays européens, ce produit ne doit pas être éliminé comme des ordures ménagères.

Recyclez-le dans les sites adaptés qui vous seront indiqués par les autorités locales ou renseignez-vous auprès de votre fournisseur.

En veillant à ce que ce produit soit éliminé correctement avec un traitement, une collecte et un recyclage adaptés, vous contribuez à éviter son action nocive potentielle sur l'environnement et la santé humaine.

Fr



Smaltimento di attrezzature elettriche ed elettroniche consumate

Questo simbolo (il simbolo della pattumiera con rotelle barrata) indica che nei paesi europei questo prodotto non deve essere buttato nei rifiuti domestici.

Per favore smaltire in luogo addetto al riciclo, dove esistente, chiedendo informazioni alle autorità locali o a chi fornisce consulenza a proposito.

Garantendo uno smaltimento adeguato di questo prodotto (trattamento, recupero e riciclo corretto), aiuterete a prevenire effetti negativi sull'ambiente e sulla salute dell'uomo.

It



Eliminación de residuos de aparatos eléctricos y electrónicos

Este símbolo (un cubo de basura tachado) indica que en los países europeos este producto no deberá eliminarse como si se tratara de un residuo doméstico. Solicite asesoramiento sobre reciclaje a las autoridades locales o a su distribuidor, y siga la normativa en materia de gestión medioambiental y reciclaje de este tipo de residuos.

Si toma las medidas pertinentes para que este producto se elimine mediante un tratamiento, recuperación y reciclaje adecuados, contribuirá a evitar posibles efectos negativos en el medio ambiente y la salud humana.

Sp

2. Preparation

2-1 | Accessories

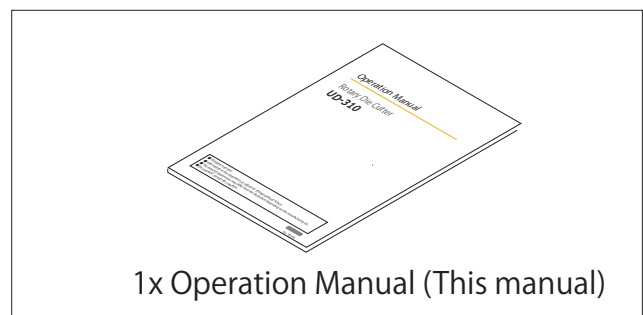
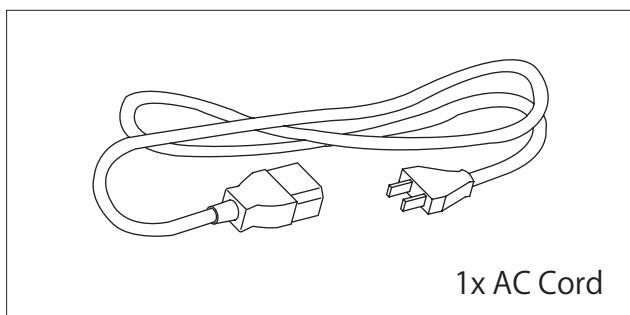
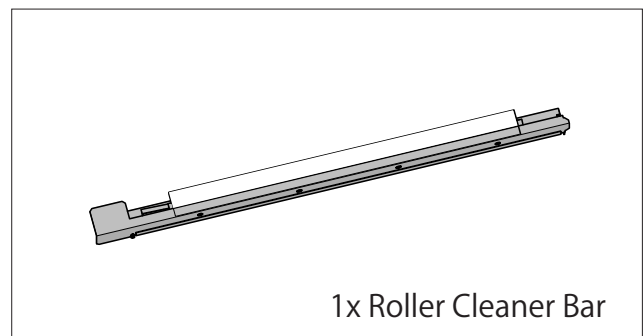
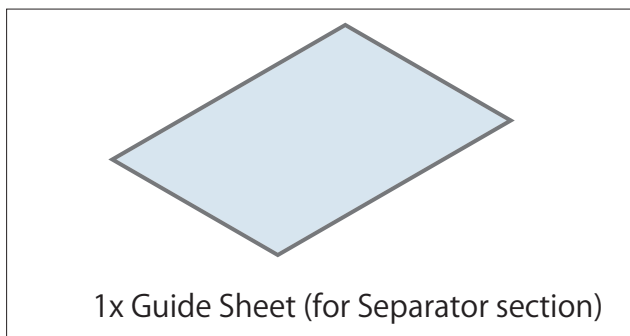
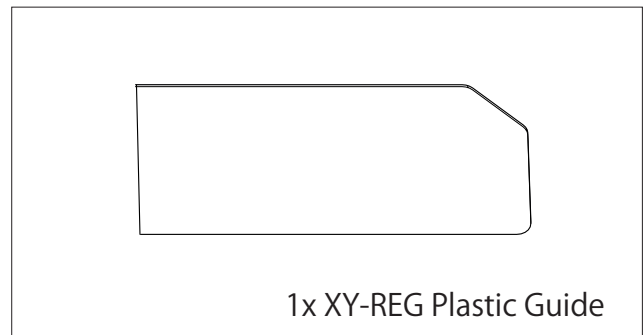
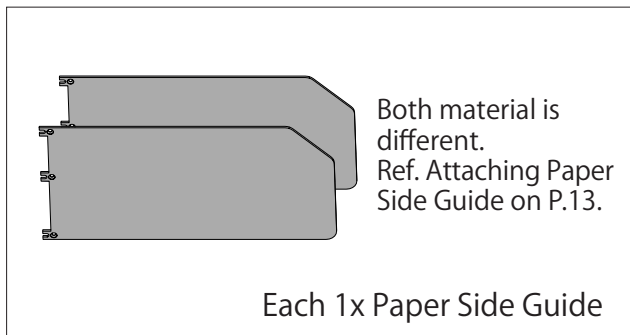
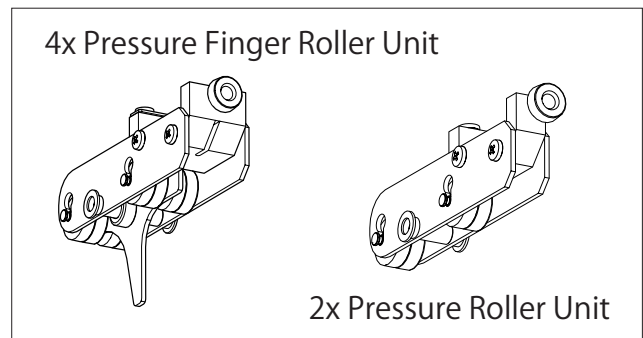
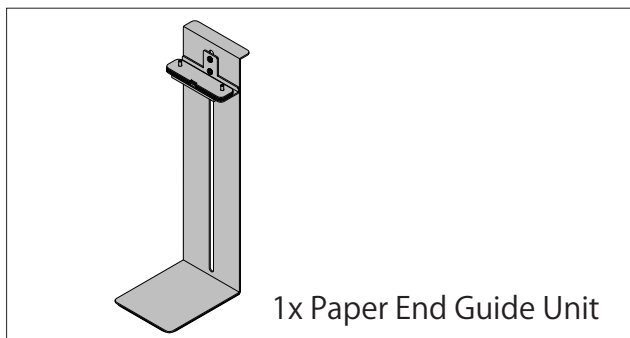
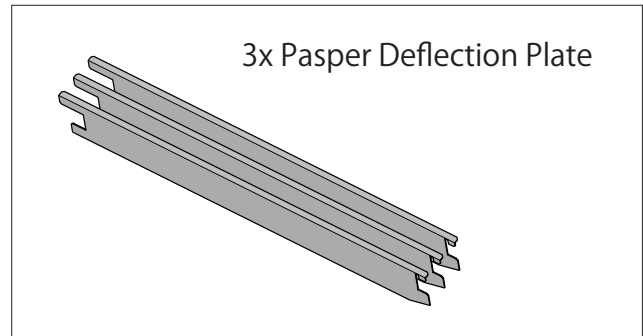
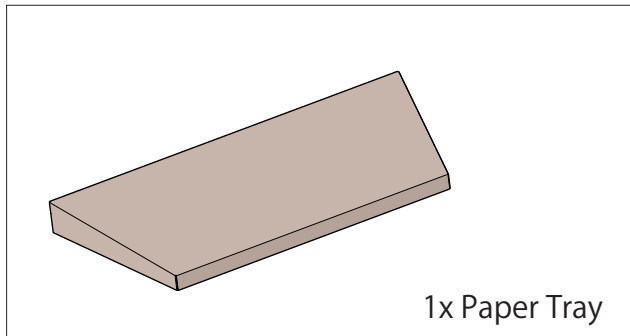

2-2 | Unit Assembly

Removing the wrappings on the Magnet Cylinder and Backer Roller before use

Remove the anti-rust wrapping paper around the Magnet Cylinder.



Remove the cushions between the Magnet Cylinder and the Backer Roller.



After removed all wrapping materials...
Wipe and clean up on the Magnet Cylinder and the Backer Roller.
After cleaning, wipe with a dried cloth dust impregnated with lighter oil only around the Magnet Cylinder for rust prevention.

Backer Roller: Alcohol
Magnet Cylinder: Oil (light type)



* Connection of the power cord... Plug in the where has 15A consistently

Attaching the Paper Side Guide on both sides

2 x Paper Side Guide look the same but the material is different.

NOTE

Non-operator side needs to be stick to the magnet. "XY-REG Plastic Guide" (ref. "2-1:Accessories") needs to be attached on non-operator side by magnetic. Operator side is stainless plate.

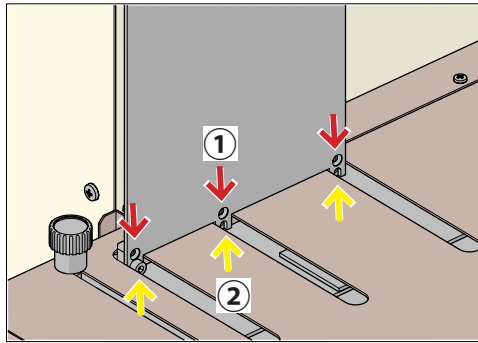

- ① Fix the "Flat Head Screw" on 3 locations, first.
- ② Fix the "Cap Screw" on 3 locations.

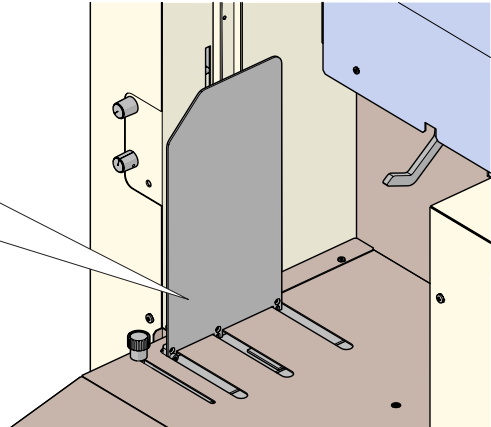

Please change the position of Paper Side Guide (Loosen by knob) when attach the Paper Side Guide on non-operator side for easier access.

Attaching the Paper Feed Table to the equipment body.

Fix with the screws on 3 location.

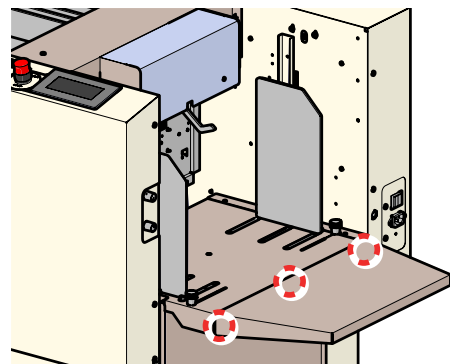
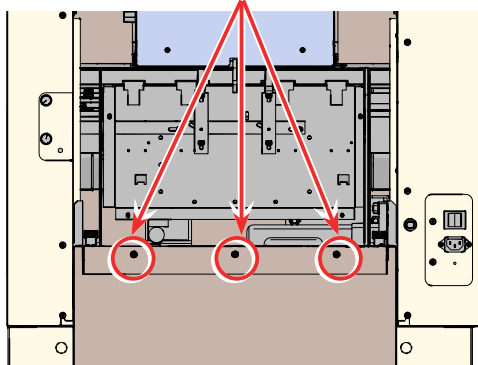

Removing the cushions under the paper tray before use

Remove the under cover of Paper Tray

The under cover is fixed by M3 screws on 3 locations. Remove them.

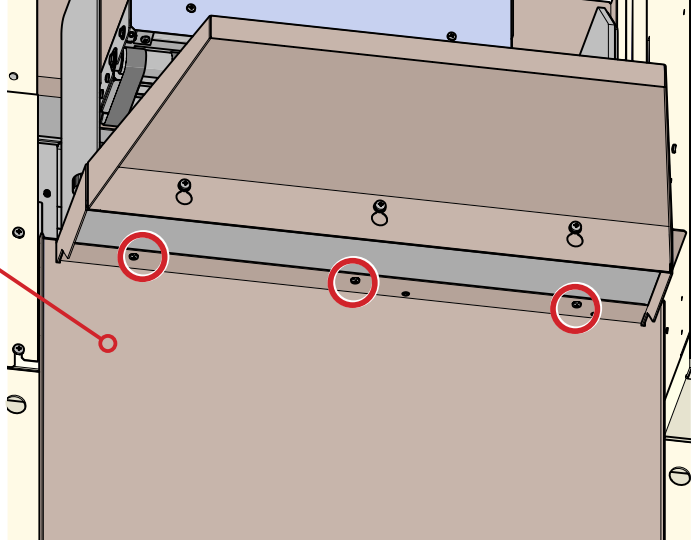

2 cushions are under the Paper Tray for shipping. Removal them.

- 1) Power on.
- 2) Push "Start (① -2)" and wait for until the machine stops automatically.(about 10 secs.)
Attention: The die station also works at the same time.
- 3) Remove the cushions.



The cushions are fixed by the following process.

1. Put into under the Paper Tray.
2. Press and hold Stop Button to lower the paper tray.
(Not too much press or the paper tray is broken)
3. The Paper Tray is fixed because of the cushions.

*** These cushions are must for when this machine is moved (shipping) to another place.**



3.Name of Parts

[Appearance]

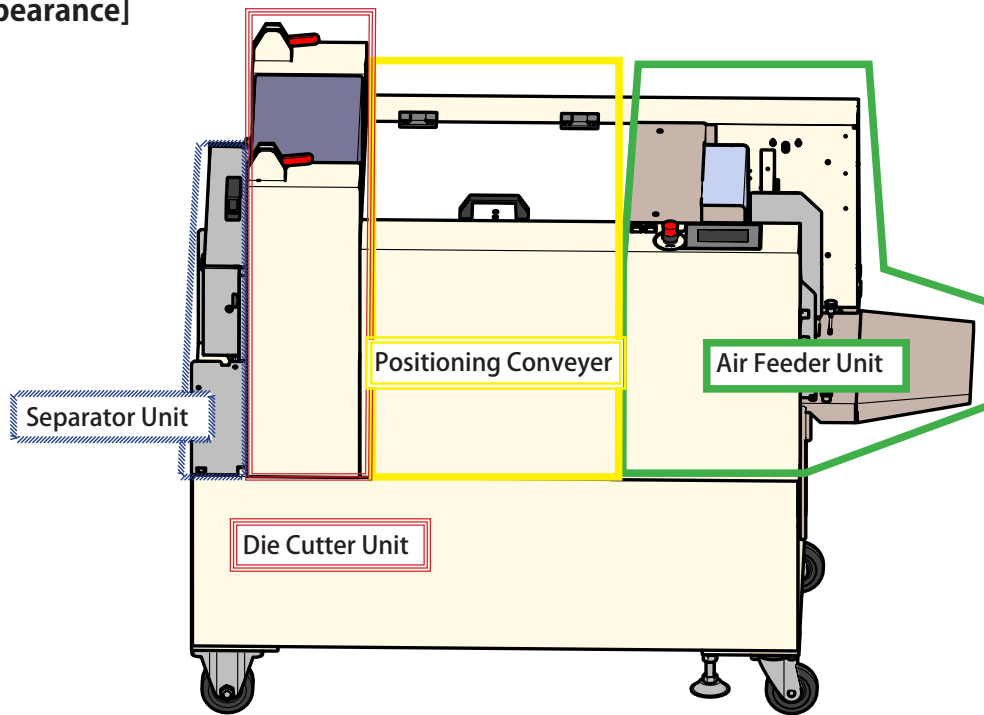

3-1 Air Feeder Unit

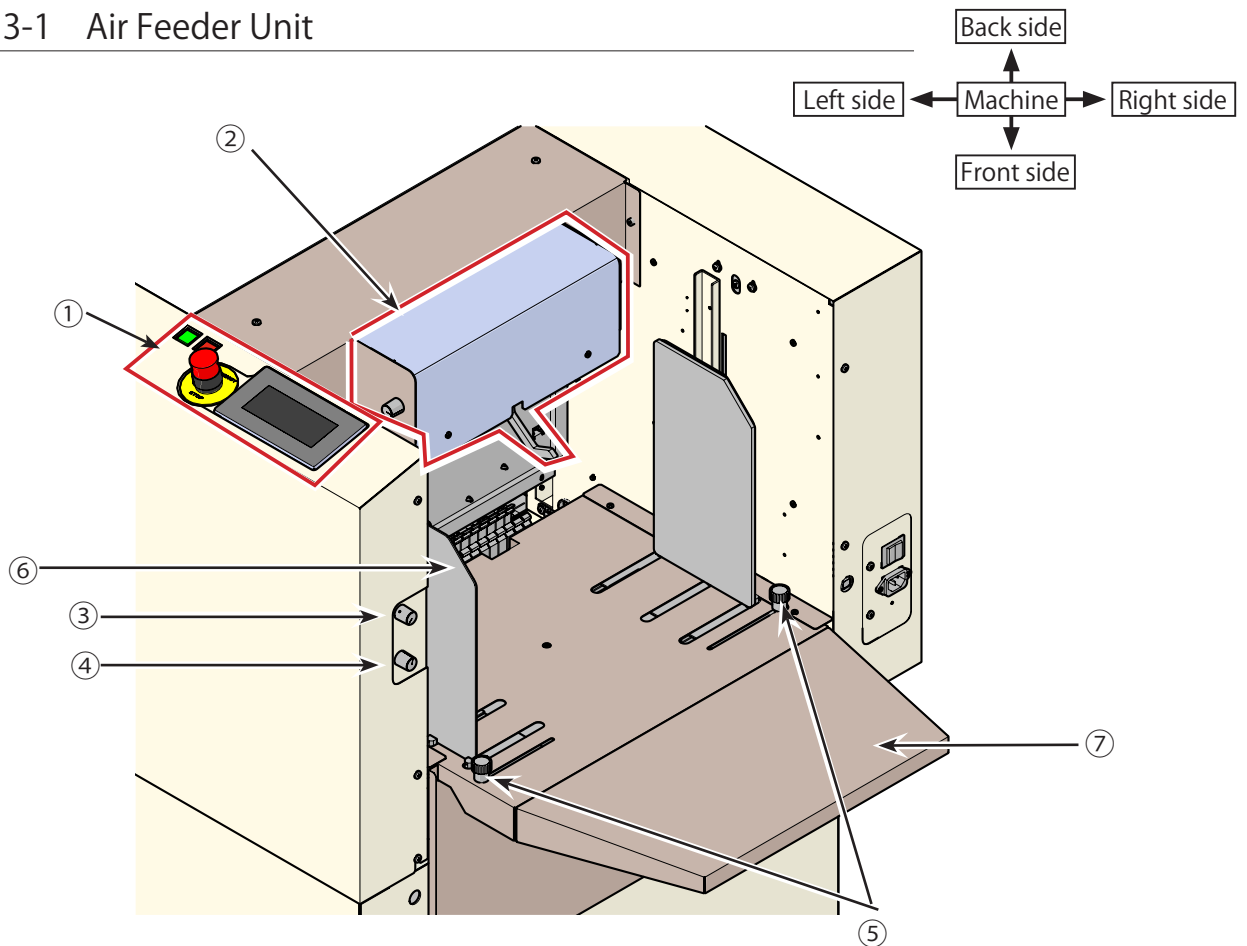

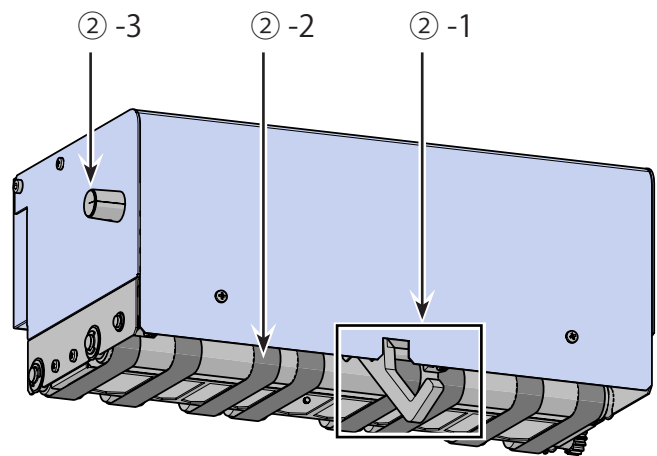
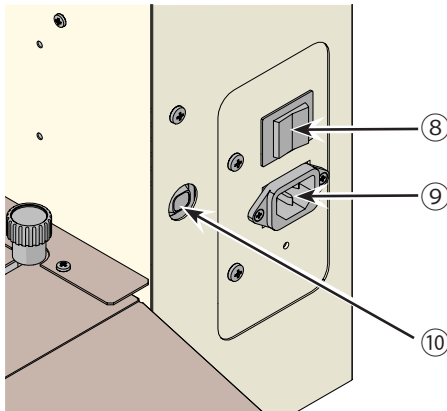
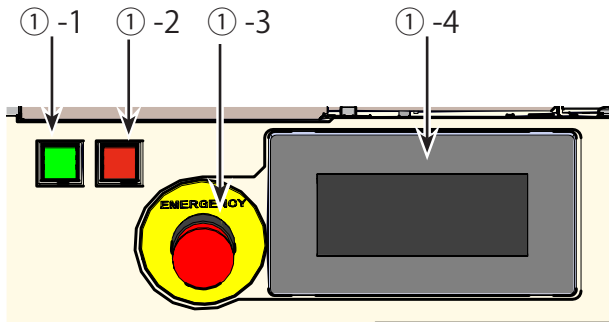

Number	Name	Job
①	Operation Panel	Operate the machine by this touch panel.
① -1	Start Switch	Start to operate. (For stable feeding, feeding starts after 5 sec.) [Feeding Adjust Mode] To call Feeding Adjust Mode, hold Start Switch and press the Power Switch to ON. (Refer "4-1" P. 24) Double beep tells (when you push this switch) that the machine doesn't work because of the covers are open somewhere or emergency switch turns on.
① -2	Stop Switch	Stop operation. Once: Last fed paper is processed and machine stops. Twice: Last fed paper is NOT processed and machine stops right there. Long press: Press longer when machine doesn't work, Paper Tray lifts down while switch is pushed.
① -3	Emergency Stop Button	Push this button when emergency. The machine stops right away.
① -4	Touch Panel	Set the operation conditions.
②	Air Suction BOX	Paper is vacuumed by this BOX for feeding.
② -1	Detection Bar	Adjust the Paper Tray height. Combine adjusting with ③
② -2	Feeding Belt	These belts feed the papers.
② -3	Adjust Knob for Detection Bar	Adjust the Detection Bar position by this knob.
③	Air Volume Adjust Knob	Adjust the air volume by this knob. Combine adjusting with ② -1
④	Double Feeding Prevent Adjustor	Adjust the height of Double Feeder Prevent Rubbers by this knob.

Number	Name	Job
⑤	Fix Knob for Paper Guide	Fix by these knobs after the paper guides set.
⑥	Paper Side Guide Plate	Guide the papers.
⑦	Paper Tray	Put the papers here.
⑧	Power Switch	Turn the machine on and off by this switch.
⑨	Power Cord Inlet	Insert the Power Cord here.
⑩	Circuit Protector	The center button comes up when the electrical circuit gets damage. Push the button and resume operation.
⑪	L-Type Paper Guide	This guide prevents the paper fly away because of air blust.

When operate as XY registration function







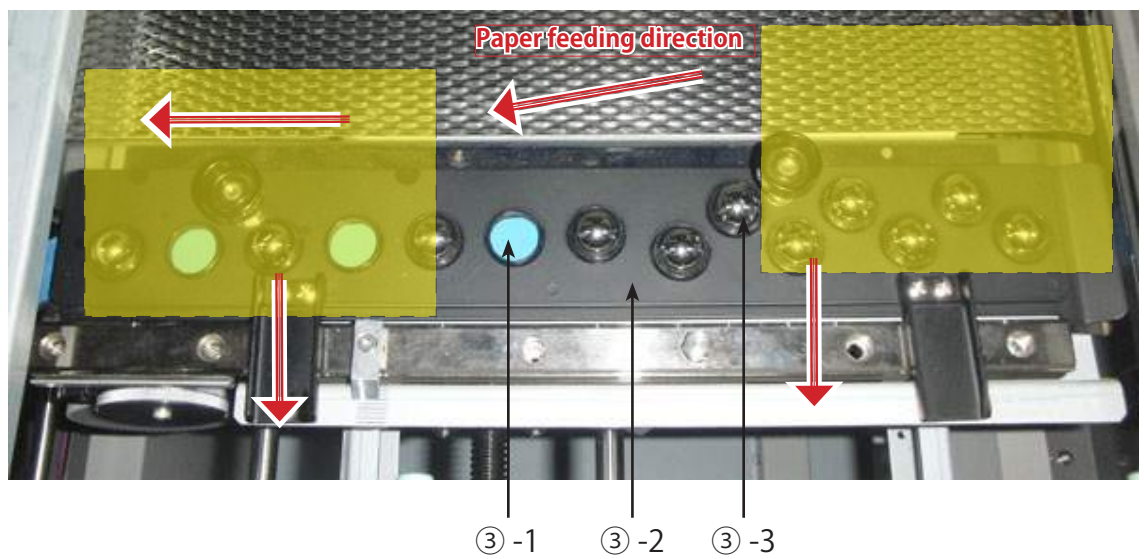
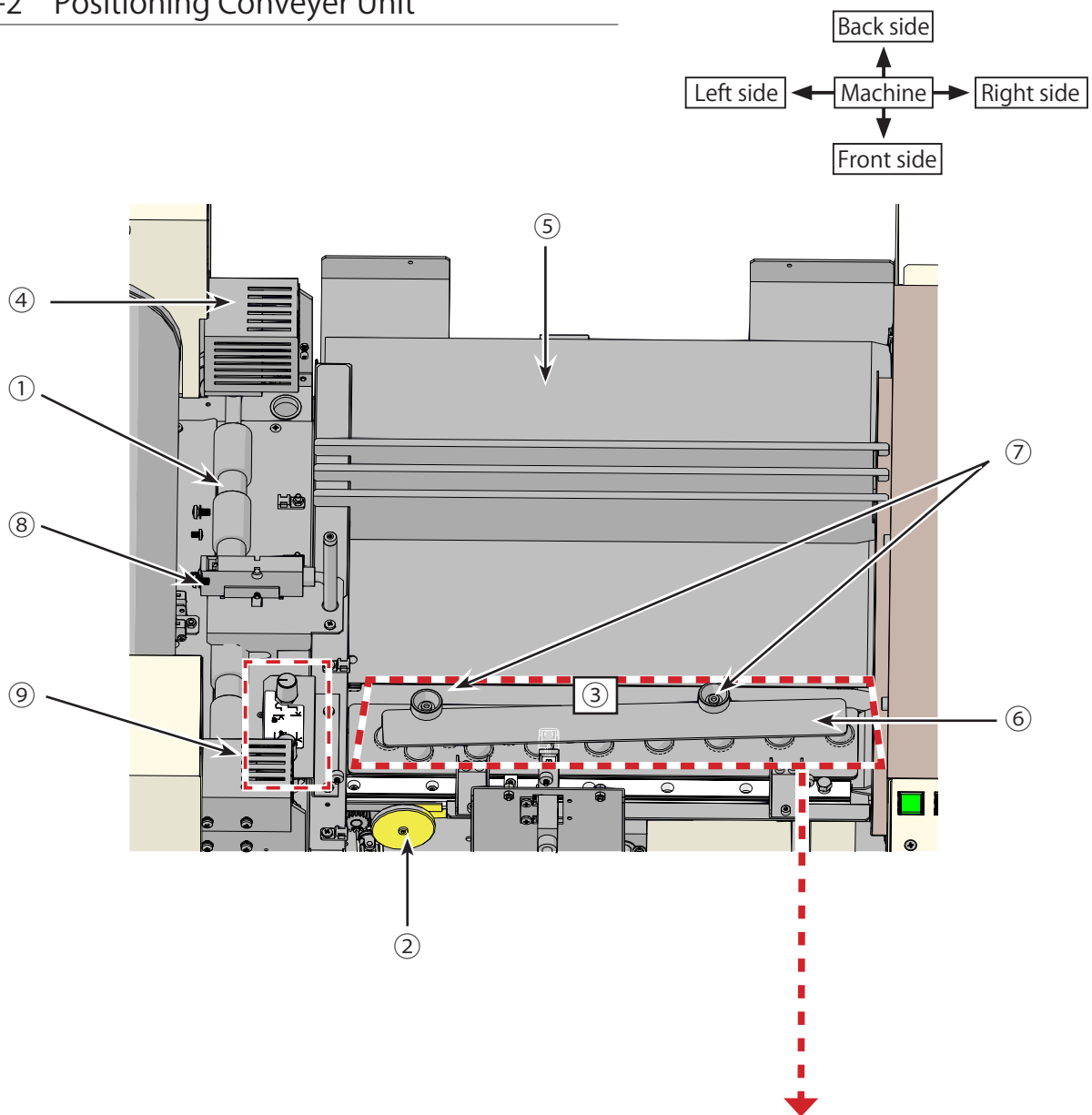

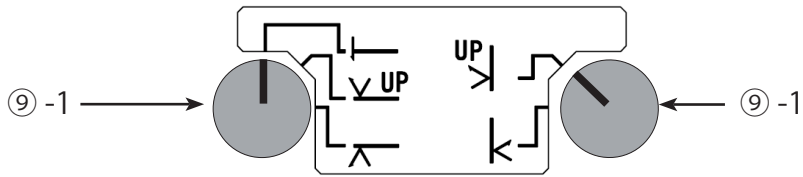
Number	Name	Job
①	XY-REG Plastic Guide (Gray color plastic parts)	*This plate is necessary for positioning when use XY function. Put the 6mm thickness plastic on the Right Side Guide. The plastic plate can be attached to the Right Side Guide by magnetic parts.

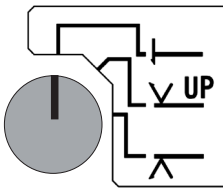
3-2 Positioning Conveyor Unit



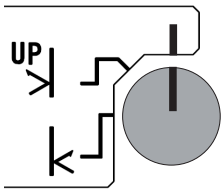

Number	Name	Job
①	Press Roller	Control the paper feeding to Cylinder station.
②	Paper Skew Adjust Knob	Adjust this knob when the paper runs askew or die cutting is askew.
③ -1	Feeding Belt	Makes the paper runs along the paper guide.
③ -2	Ball Holder	Holds the balls.
③ -3	Metal Ball / Plastic Ball	Weight for paper feeding. Creatively use Metal and Plastic balls, holding places for paper conditions.
④	Solenoid for Press Roller	Lift up and down for Press Roller. There is 1 on each side.
⑤	Feeding Guide Plate	Special guide plate for anti static.
⑥	Balls Guide	Hold the steal balls (weight).
⑦	Balls Guide Fixing Knob	Loosen this knob when adjust the steal ball positions and numbers.
⑧	1st Cylinder Sensor	Read the first paper edge and make it stop at the right position.
⑨ -1	Sensor Switching Knob LEFT "Y Registration reading" 	1) Paper Edge Reading  Read the paper edge. 2) Face up Registration Mark Reading  Read the Register mark on top face. 3) Face down Registration Mark Reading  Read the Register mark on underface (bottom face).

<p>⑨ -2</p>	<p>Sensor Switching Knob RIGHT "X Registration reading"</p> 	<p>1) OFF position Do not use this position when read both X and Y registration mark, or the fed sheet stop at the positioning conveyer as error.</p> <p>2) Face up Registration Mark Reading</p>  <p>Read the Registration mark on top face (face up).</p> <p>3) Face down Registration Mark Reading</p>  <p>Read the Registration mark on underface (face down).</p>
<p>⑩</p>	<p>Eyephole for paper skew adjust</p>	<p>The relationship with this hole and screw position shows you which way you need to adjust the skew and present position.</p>
<p>⑪</p>	<p>Paper Deflection Plates</p>	<p>Prevent the paper fly away or curl upward.</p>

3-3 Magnet Cylinder Unit

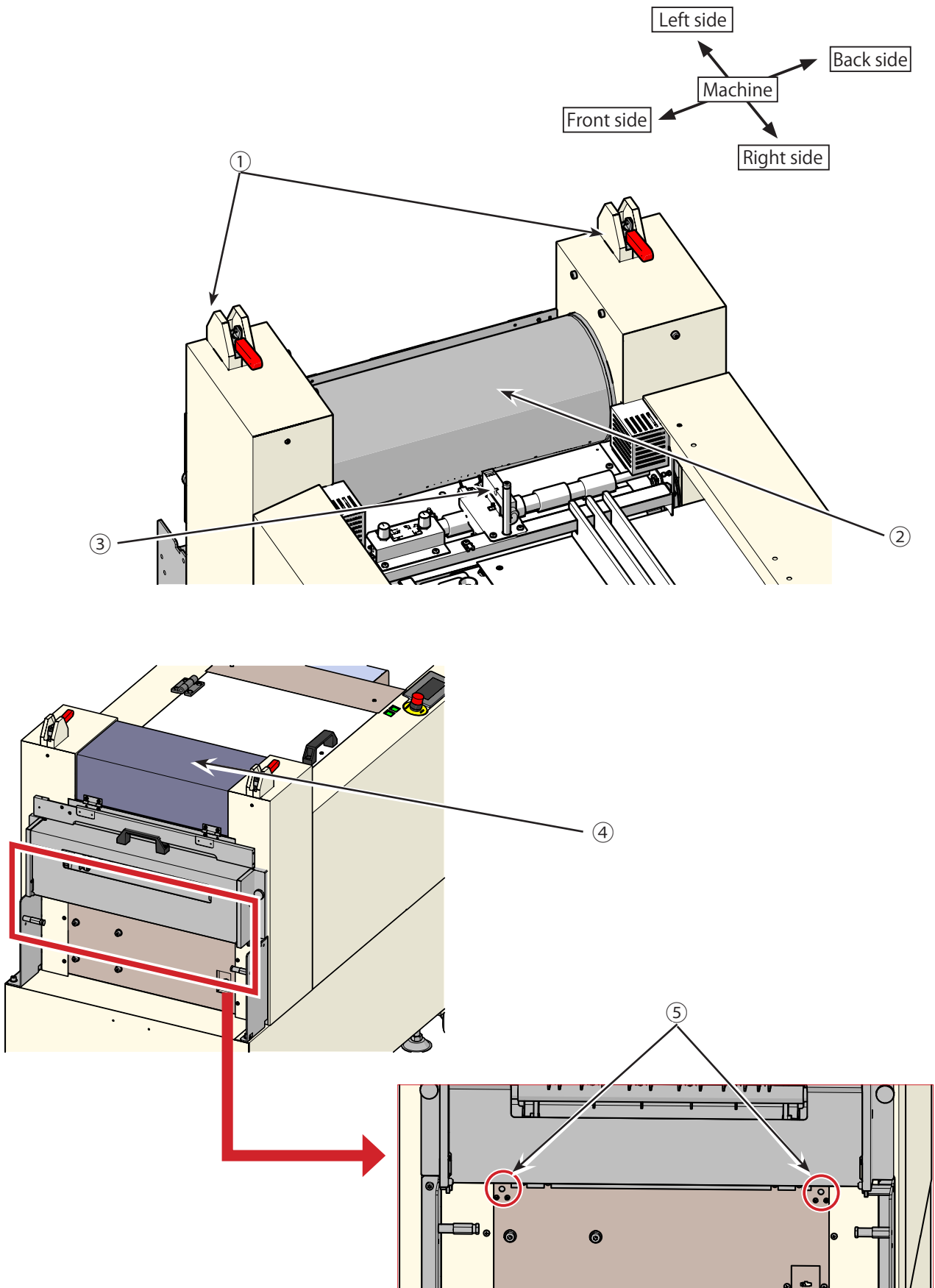

Number	Name	Job
①	Cylinder Lock Lever	<p>Lock Lever of Magnetic Cylinder.</p> <p>Lock: Lever down to the separator direction.</p> <p>Unlock: Lever down to the feeder direction.</p> <p>Lever down to the separator direction when operation. Lever down to the feeder direction when remove jammed paper between cylinders.</p>
②	Magnetic Cylinder	Set the Die Plate here. This is the main important parts of this machine.
③	Paper Sensor	Control the paper feeding timing for the Magnetic Cylinder rotation.
④	Safety Cover	<p>Safety Cover for Die Station.</p> <p>* Wait for a second and operate when you open this cover. The brake is just released and turn a little.</p>
⑤	Oil supply hole	<p>Oil supply hole on both sides for daily maintenance.</p> <p>Please refer the detail on Daily Maintenance page on this manual.</p>

3-4 Separator Unit

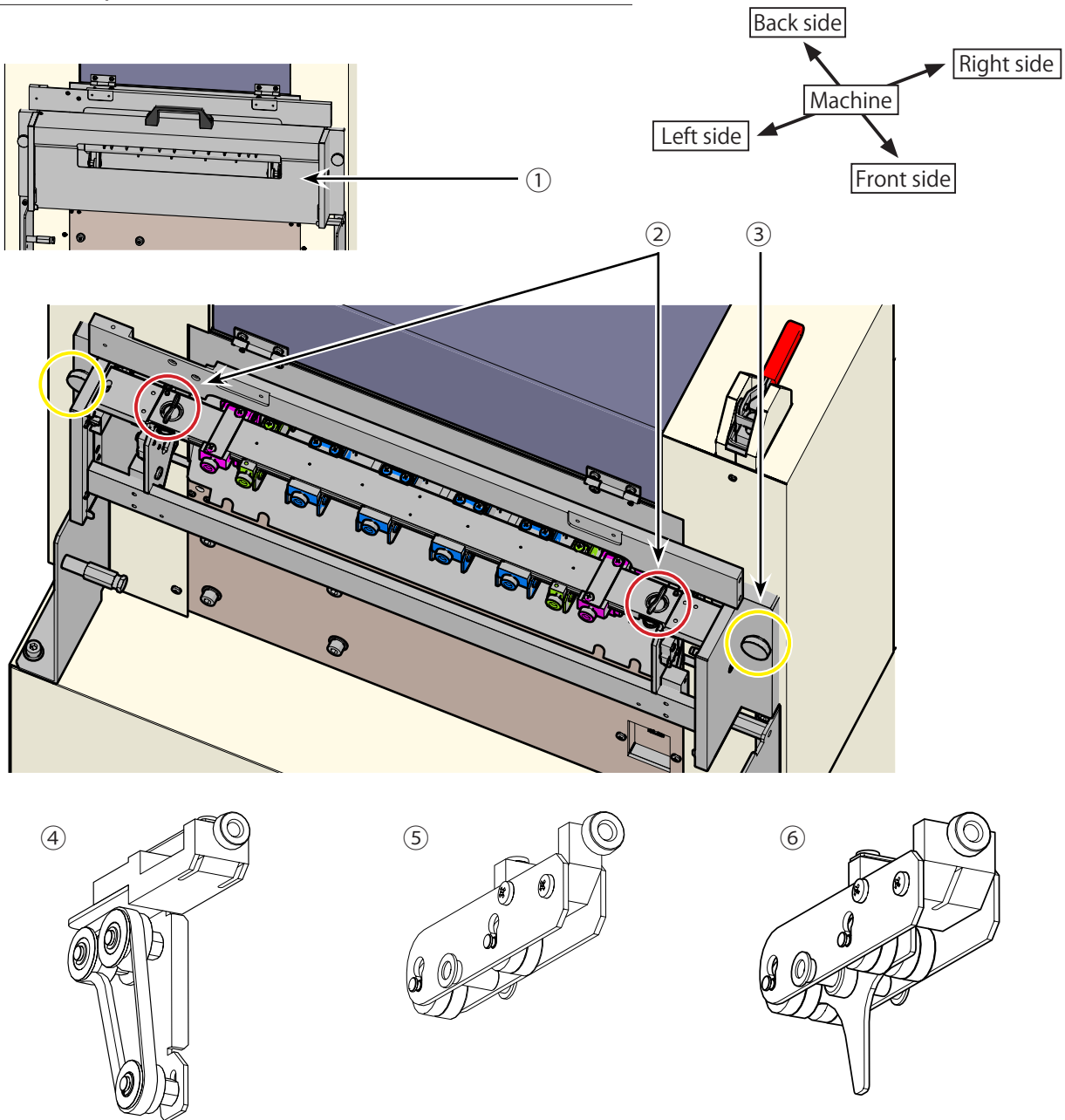

Number	Name	Job
①	Separator Cover	Separator Cover. The machine doesn't work if this cover is not at the correct position because of safety security.
②	Lock Key	Loosen this Lock Key when remove the separator cassette unit. Customer can order this whole cassette unit for each jobs.
③	Separator Unit Fix Knob	Separator section is fixed by this knob on both side. Loosen this knob on both sides and open the Separator section when paper jam happens.
④	Separator Belt Unit	Deliver both side of wasted paper area (skeleton part) to a trash bin.
⑤	Separator Nip Roll Unit	Support to discharge the cut pieces. Use this for stable separation especially at next to Separator Belt Unit on both sides.
⑥	Separator Finger Roll Unit	Finger parts deliver the easted paper area (skeleton part) to a trash bin. White roller parts support to discharge the cut pieces.

4.Operation Process

4-1 | Loading of Paper

[Feeding Adjust Mode]

To call Feeding Adjust Mode, hold Start Switch and press the Power Switch to ON.
Each switch jobs as Feeding Adjust Mode is as below.

Refer "3. Name of Parts (P.16)" for the location of switches.		
① -1	Stop Switch	Stop to work
① -2	Start Switch	<p>Once: Keep to be ready for feeding start after Paper Tray lifts up the regular position. Adjust the feeding conditions with this state. Push Start Switch again after push Stop Switch and machine stops working, you can use as Feeding Adjust Mode again.</p> <p>Twice: Push Start Switch again when the machine keeps to be ready for feeding, machine works as normal mode. When call up Feeding Adjust Mode again, turn off Power Switch, and hold Start Switch and press Power Switch to ON.</p>

(1) Paper Set

Put the sheets on the Paper Tray. Adjust the Paper Guide Plate and Bar along the sheets as center position.
Make a gap (about 2 mm) between the sheets and the Guide when the thick papers are used.

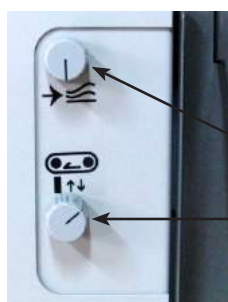

Air Volume Adjust Knob
Double Feeding Prevent Adjustor

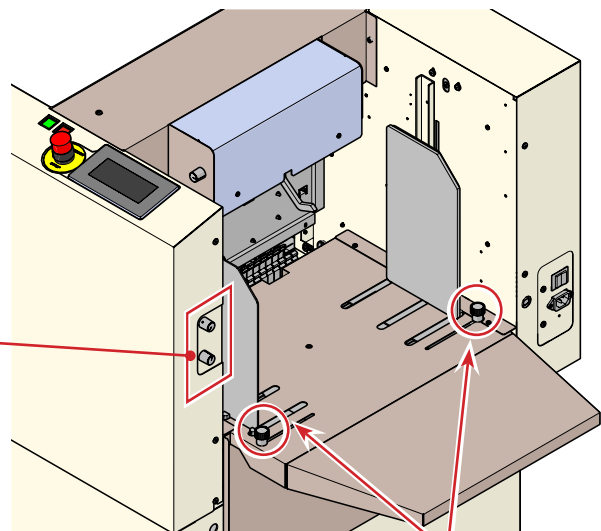

Fixing Knob

Crease process : Paper set as printed face down
Label process (Half cut on printed face) : Paper set as printed face up

(2) Adjust the air volume and the double feeding prevention

Adjust air volume.
The shutter of air outlets are shifted back and forth by the Air Volume Adjust Knob.

* "Detection Bar" must be adjusted together when set the air volume.

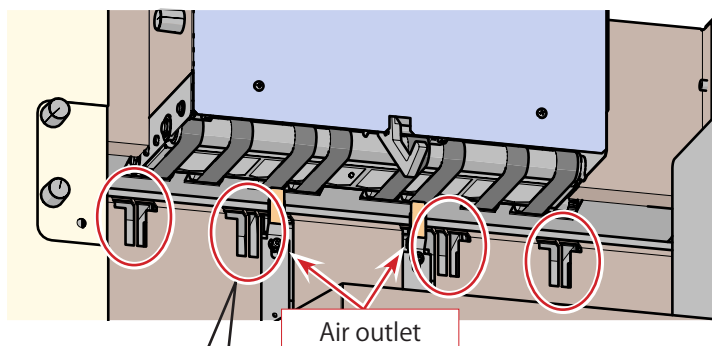

Air Volume Adjust Knob



Double Feeding Prevent Adjustor Knob

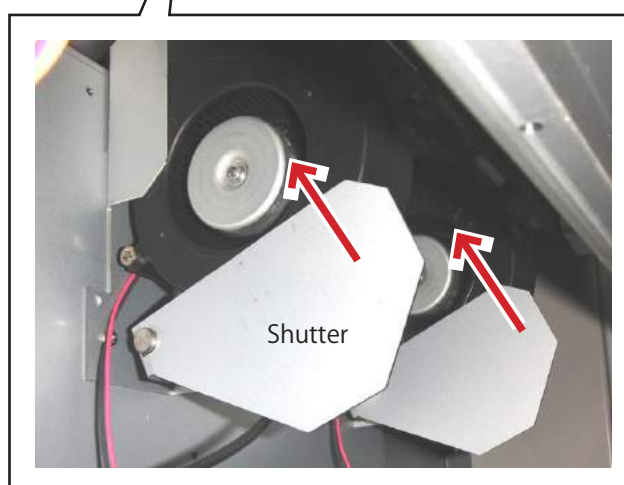

Adjust the Paper Separations.
The Paper Separations shift up and down by the Double Feeding Prevent Adjustor.
Make the rubbers hit the belts more when the double feeding is happened.
(*See below picture)

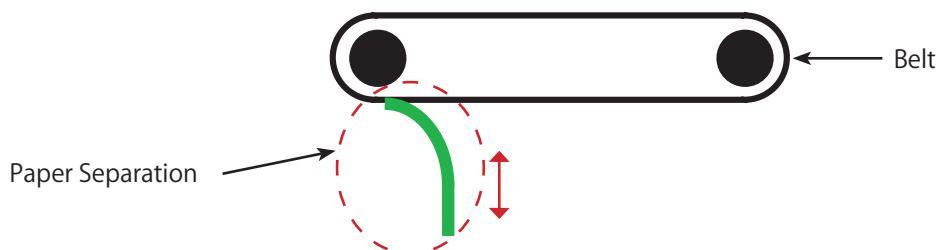
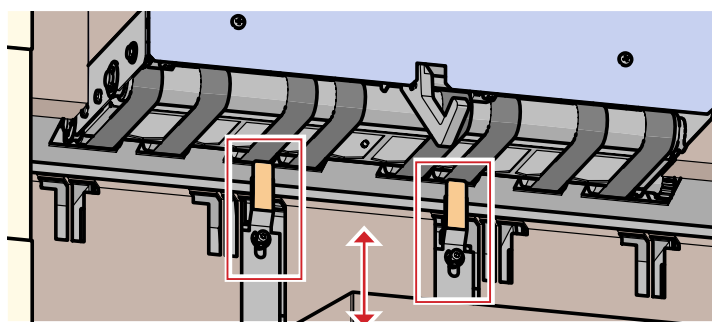

(3) Adjust the Detection Bar (paper height)

Adjust the Detection Bar.
Decide the height of the Detection Bar
by the Adjust Knob for Detection Bar.
Adjust the gap between sheets and
belts.

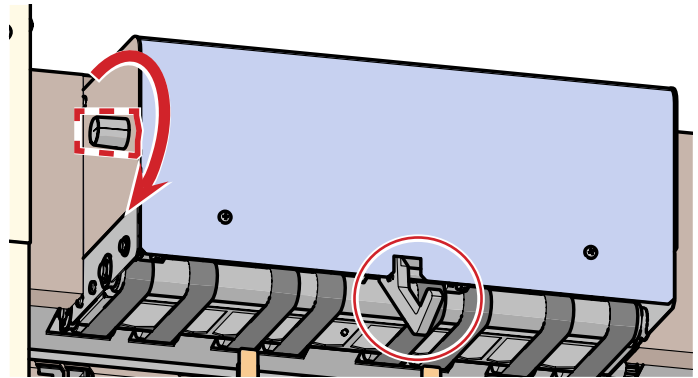

When the thick papers cannot be fed smoothly, adjust to narrow the gap.
(Do not adjust too narrow, or feeding doesn't work because of too much load.)

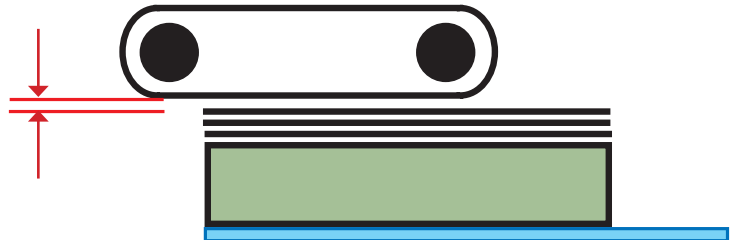

When the double feeding is happened often, adjust to wide the gap.
(Better to make the wider gap for paper separation when the thin papers are used.)

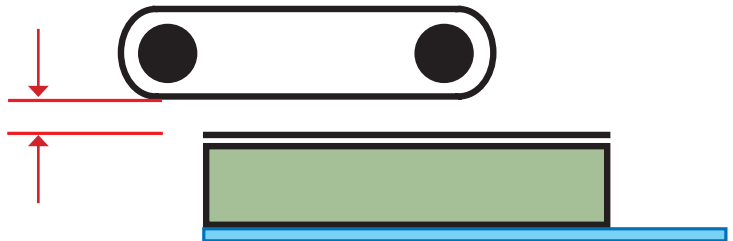

Good enough separation



Not enough separation

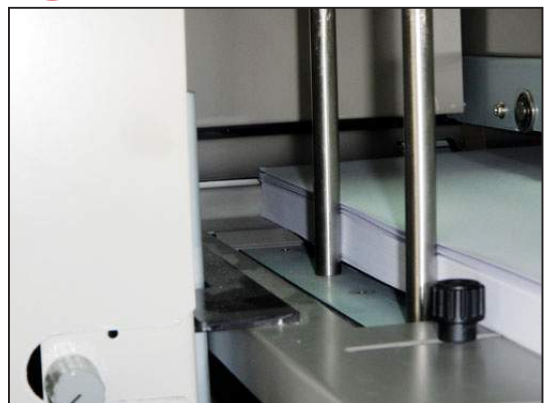

(1) Read only Y axis registration mark

※ **Reset the Paper Width setting when you change to XY REG reading from Y REG reading. (Push "Ent (Enter)" button and reset the Positioning Guide position, even if the same paper width.)**

[1] Setting touch panel

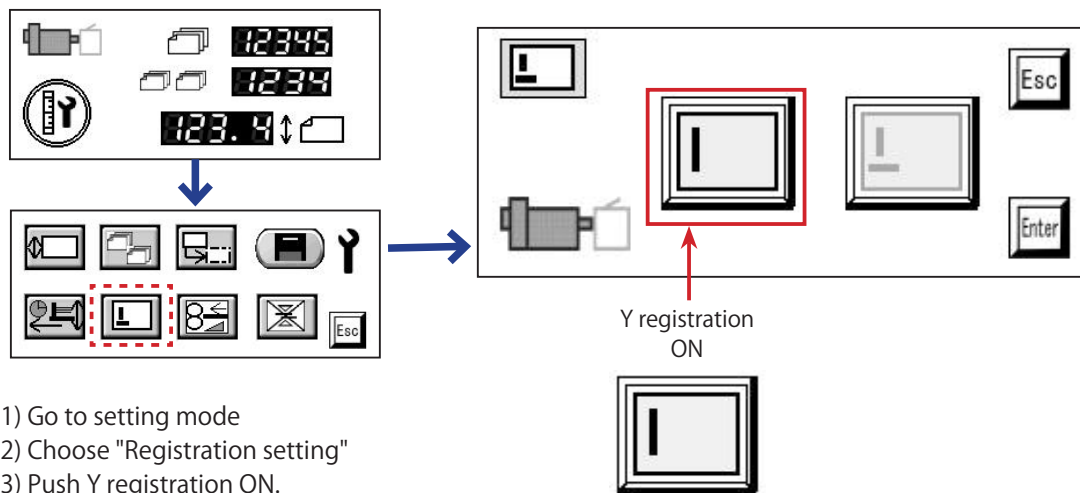

[2] Switching depends on the printed sheets.

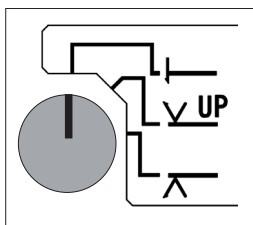

1) Read the paper edge

When the sheets don't have a Register Mark.



2) Top Register Mark Reading

When the sheets have a Register Mark on top face.



3) Underface Register Mark Reading

When the sheets have a Register Mark on underface.



[2] Register Mark details

Recommendation for register mark

- 1) Register Mark should be on the position where the sensor can read.
=> Recommendation: Register mark length is 10mm length every time.
- 2) Width of Register Mark should be more than 3mm.

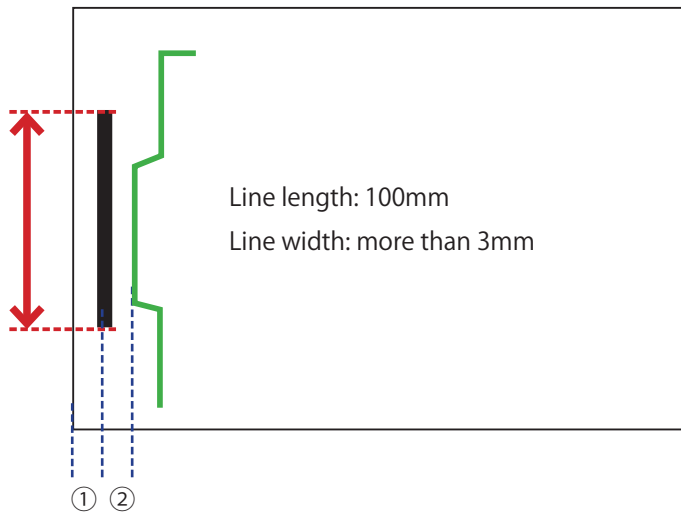

[3] Relation of Register Mark and 1st blade position.

* Sensor read the front edge of Register Mark.

- ① The Register Mark should be 10mm away from the paper edge.
- ② The 1st blade should be 10mm away from the Register Mark.

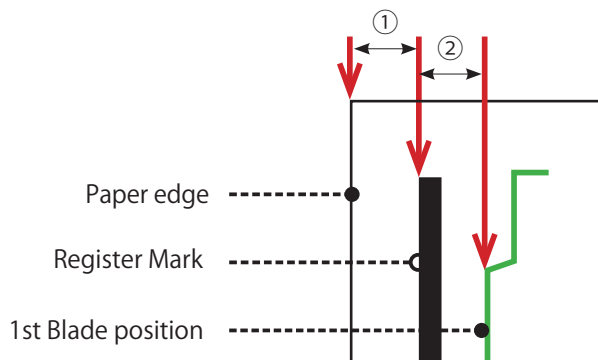

(2) Read X and Y axis registration mark

※ **Reset the Paper Width setting when you change to XY REG reading from Y REG reading. (Push "Ent (Enter)" button and reset the Positioning Guide position, even if the same paper width.)**

[1] Setting touch panel

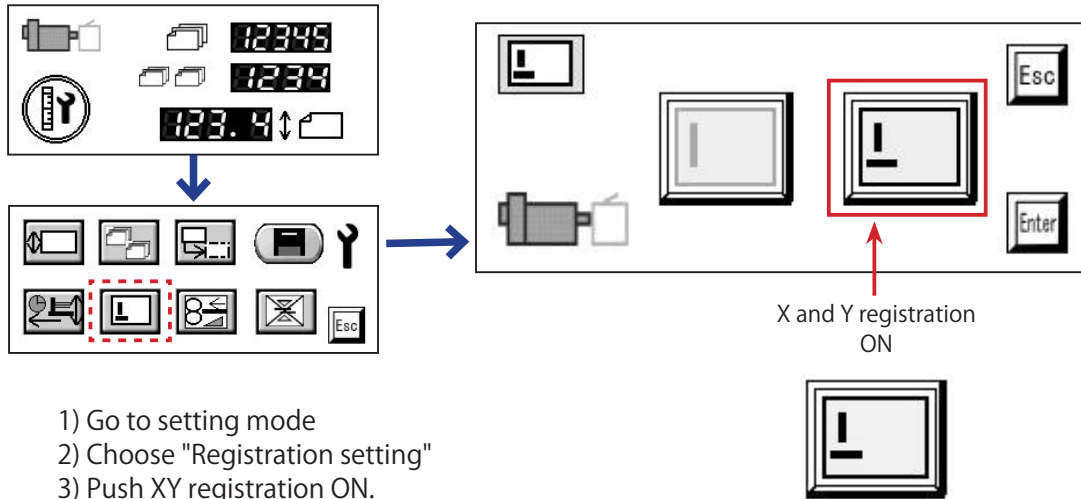

[2] Switching depends on the printed sheets.

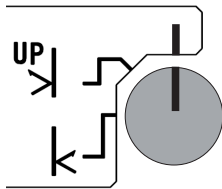

1) OFF

Do not use this position when read both X and Y registration mark, or the fed sheet stop at the positioning conveyor as error.

2) Face up Mark Reading



Read the Registration mark on top face (face up).

3) Face down Mark Reading



Read the Registration mark on underface (face down).

Make sure to put the "XY-REG Plastic Guide" on the paper guide on non-operater side. ref. "When operate as XY registration function" on [P.17].

[2] Register Mark details

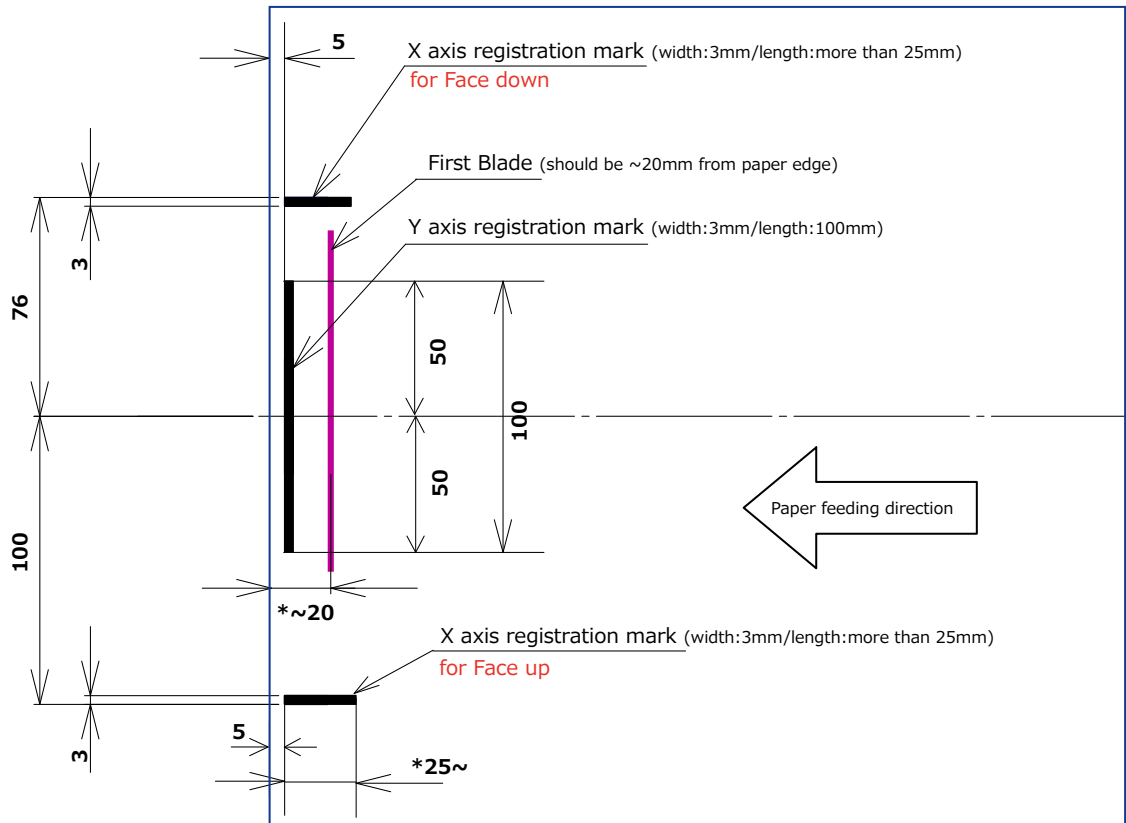

- ① X registration mark should be 3mm width / more than 25mm length.
- ② X registration mark for Face up should be 100mm away from the paper center.
- ③ X registration mark for Face down should be 76mm away from the paper center.
- ④ Both of X and Y Registration mark should be 5 mm away from paper edge.
- ⑤ Y registration mark should be 3mm width / 100mm length.
- ⑥ Y registration mark should be on the center of the paper width.
- ⑦ The first blade should be up to 20mm away from the paper edge.
The dammy blade is possible to be the first blade.

※ **Comply with this resigtration mark positions.**

Printing positions are out of the spec, the machine stops as error.
Maximum Shift: **Whithin plus-minus 2mm** from the paper center.

Possible to adjust the 1st cutting position in Maintenance mode.

4-3 | Die Plate Setting

Setting the Die Plate

Unlock the Cylinder Lock Lever on both sides.
(To feeder direction)
The Magnetic Cylinder isn't lifted up by this lever.
This lever is only "locking" purpose.

- * **Plug off the AC cord when replace the die.**
- * **Make sure to wear the gloves when handle the dies and papers.**

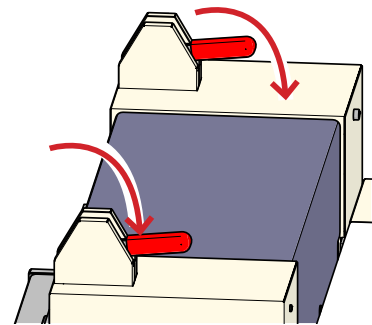

Set the Die Plate on the Magnet Cylinder

How to set the Die Plate

- 1) The 2 pins of the Magnet Cylinder pit to the holes of the Die Plate.
- 2) Hit correctly to the two of Home Position Pins by the edge of the Die Plate.

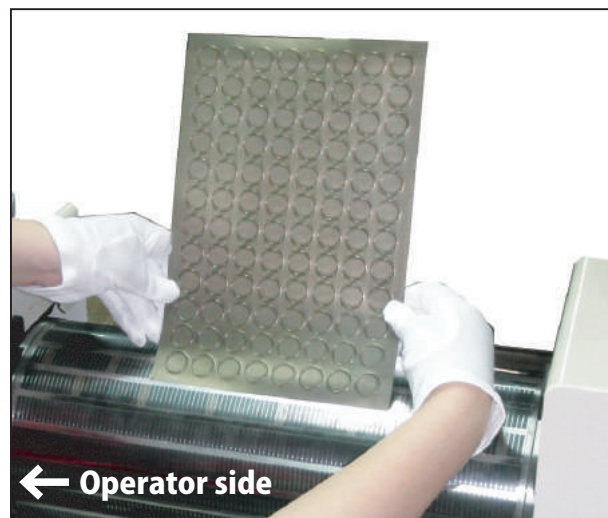

- 1) The 2 pins of the Magnet Cylinder pit to the holes of the Die Plate.

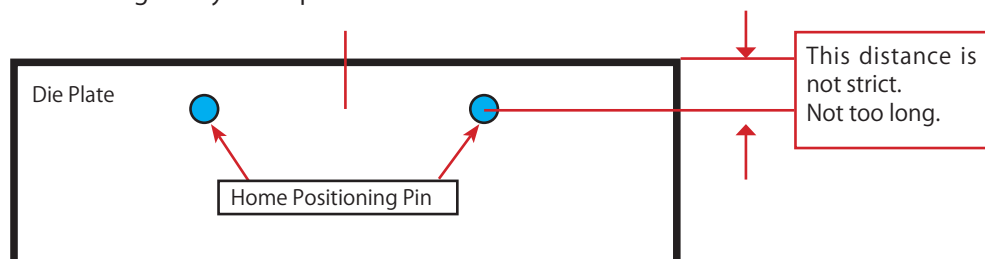

The first blade of the Die Plate should be located at 10mm distance from the plate edge.
The first cut of the paper should be located at the same 10mm distance from the paper edge.
For the case of the thin papers, distance should be 12~15mm distance.

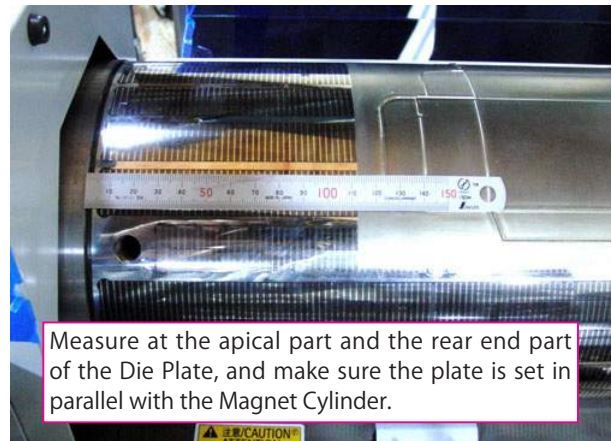
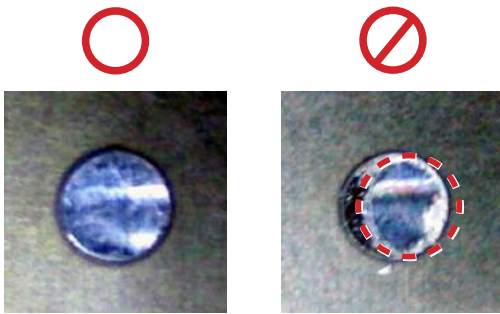
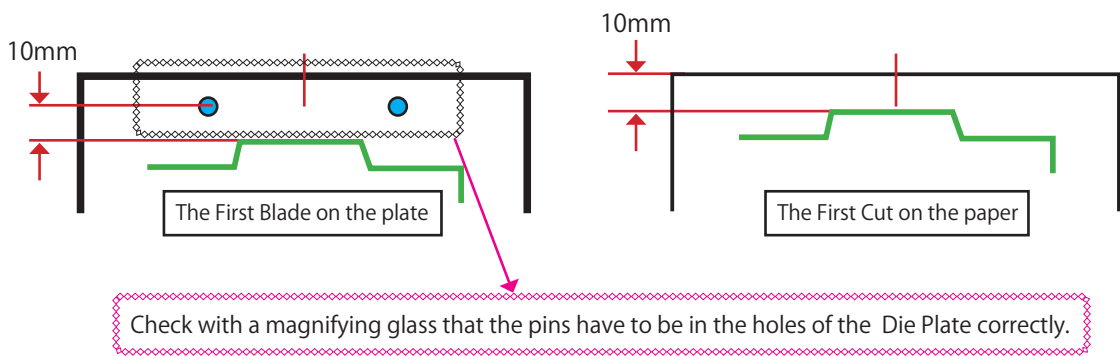

2) Hit correctly to the two of Home Position Pins by the edge of the Die Plate.

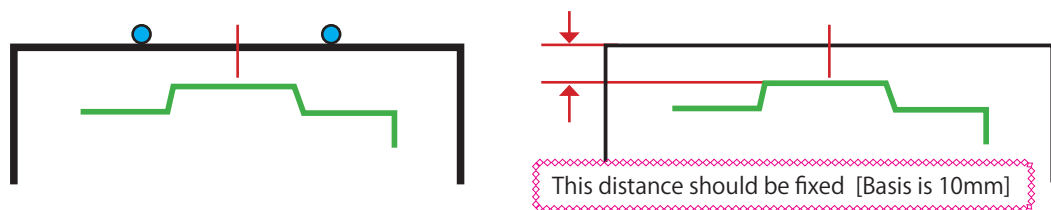

○ After setting the plate, lock the Cylinder Lock Lever on both sides. (To separator direction)

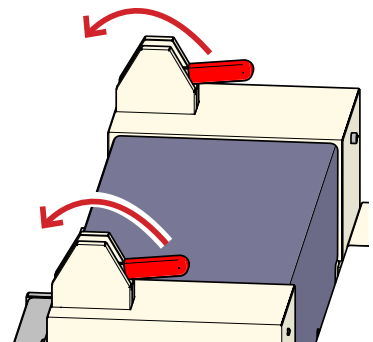

4-4 | Separator Setting

- (1) Remove the Separator Cassette from Separator section.
 - 1) Loosen the "Separator Unit Fix Knob" on both sides and open the Separator section.
※ This Separator Unit is heavy, so be careful when opening it.
 - 2) Turn the "Lock Key" counterclockwise on both sides and lift up the whole cassette.

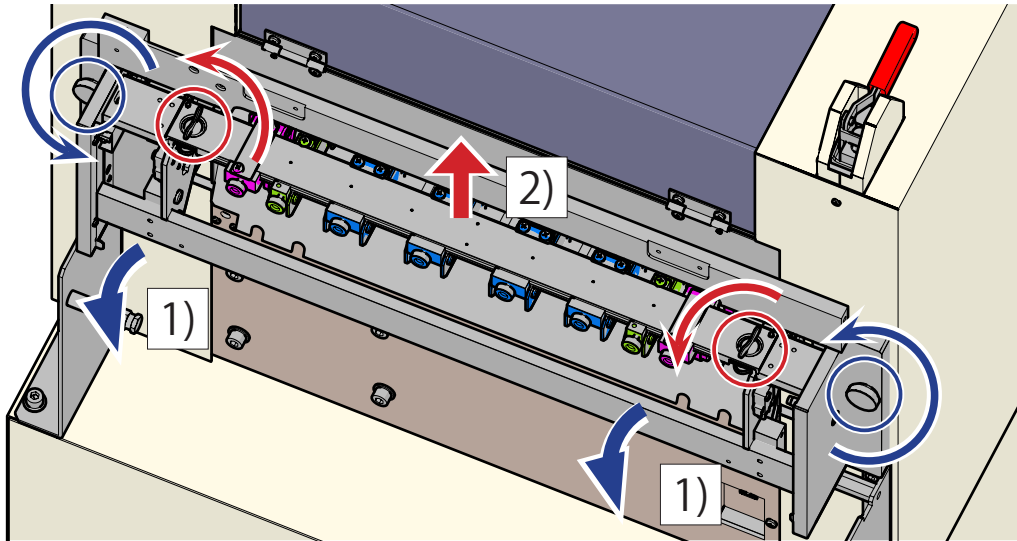

- (2) Set "Separator Finger Roll Unit", "Separator Belt Unit" and "Separator Nip Roll Unit" depending on cut design.

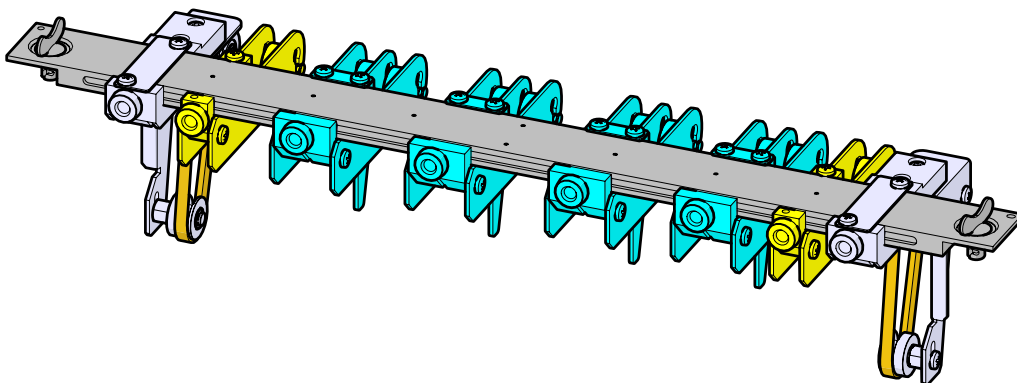

"Separator Nip Roll Unit" needs to be next to "Separator Belt Unit".
Separator Nip Roll Unit helps the cut pieces to forward direction smoothly.

1) Remove and Set

- ① Loosen the fixing knob.
- ② Set the unit.
- ③ Plate of Separator Finger Roll Unit catches the "Unit Hold Bar"

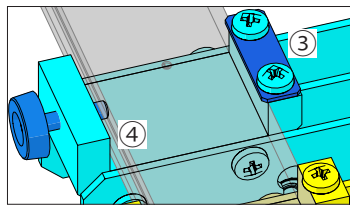

- ④ Top of fixing knob is fixed in the notch of "Unit Hold Bar"

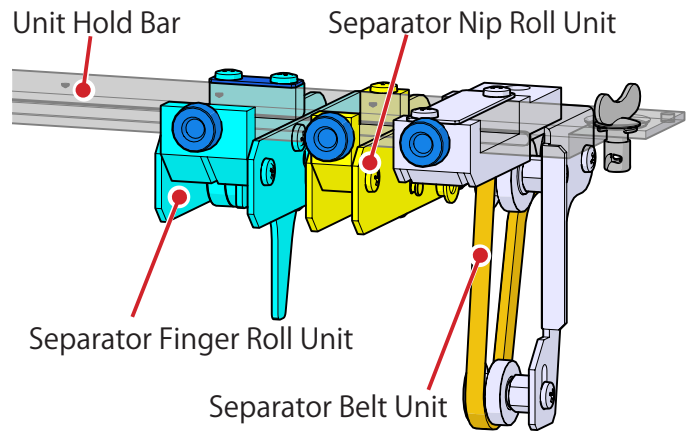

2) Fine adjustment

- ① Loosen the fixing knob.
- ② Slide the unit on the "Unit HoldBar".
- ③ Fix the fixing knob in the notch.

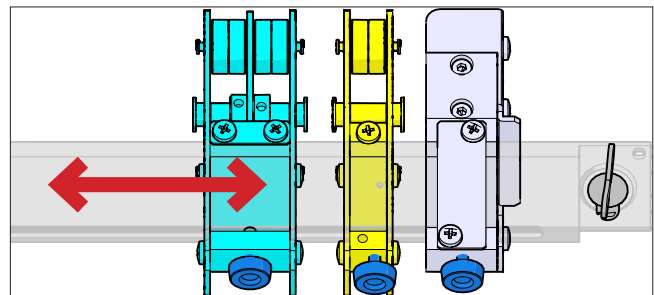

- 3) "Separator Finger Roll Unit" must be on the center of the piece which is going to be separated. The roller part of Separator Finger Roll Unit catches cut pieces on both sides.

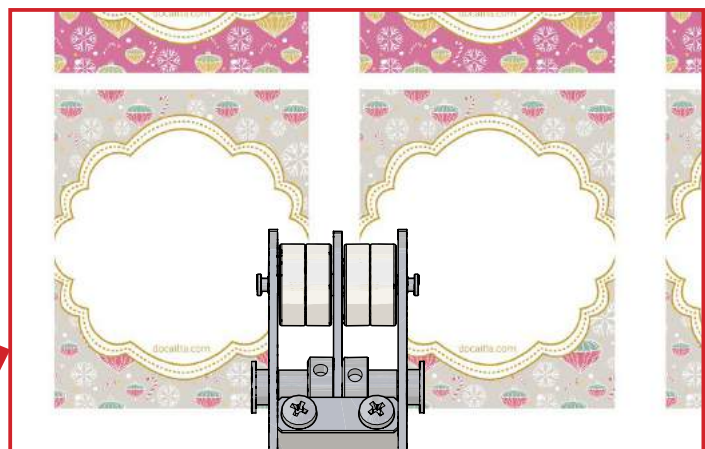
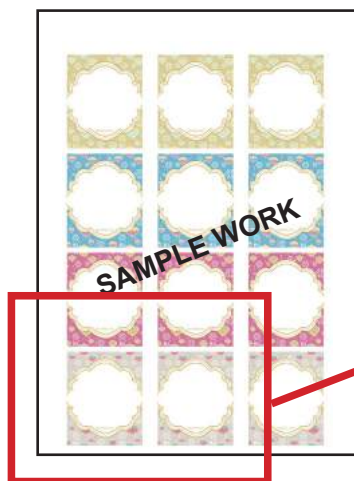

Minimum width of piece : 40 mm
Minimum length of piece: 50.8mm

Finger part places the wasted space between cut pieces.

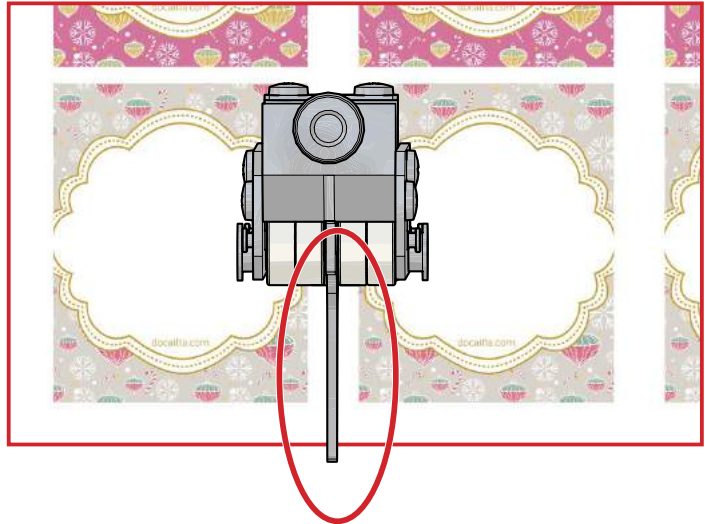

When the die plate is angled design for longer blade life arrangement, the blank space should be thought as the following image.

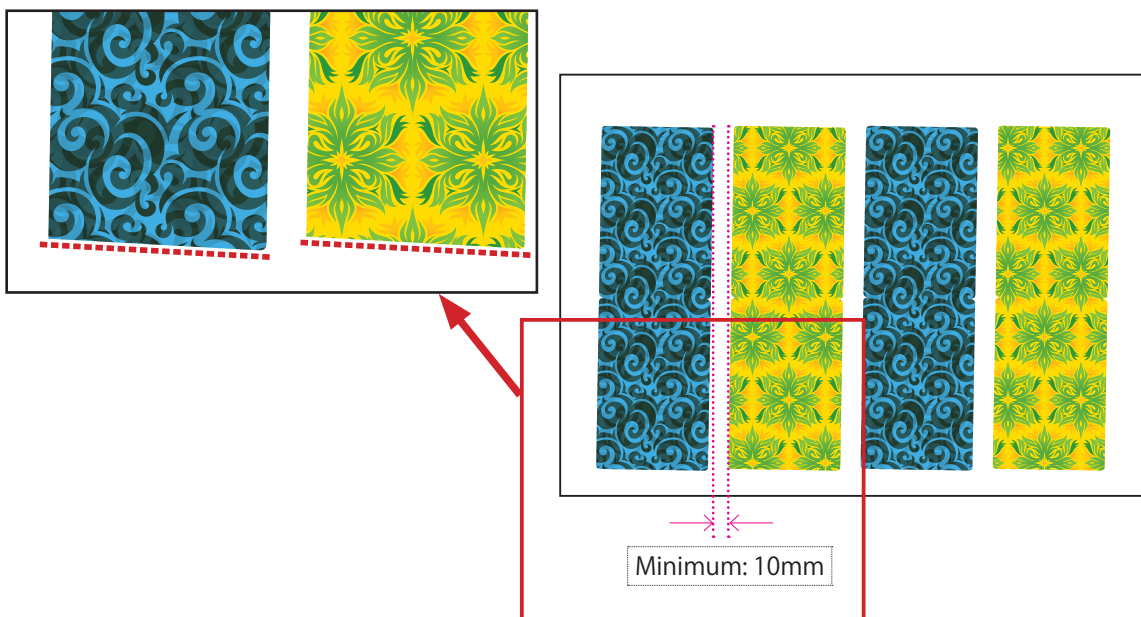

Minimum blank space between pieces: 10mm.

4) Set the Separator Belt Unit

* Belt is easy to out from the gear.

Make sure that the belt is on the gears when close the Separator Unit.

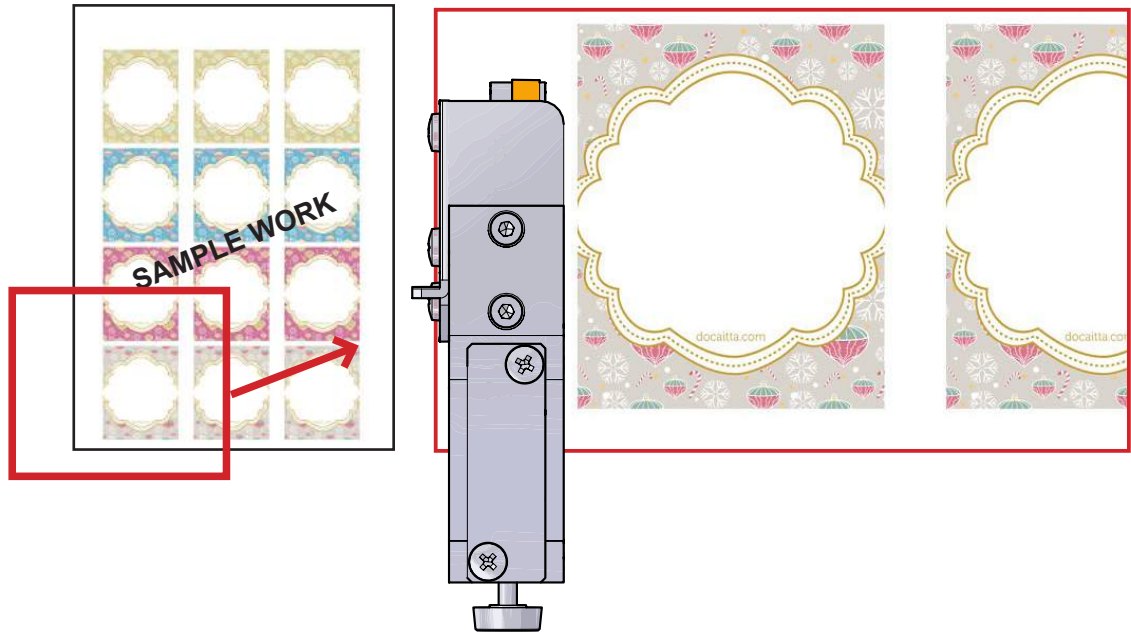

Belt Unit position should be not far from the both ends cut.
Distance from the both ends is about 5 mm. Not so sever.

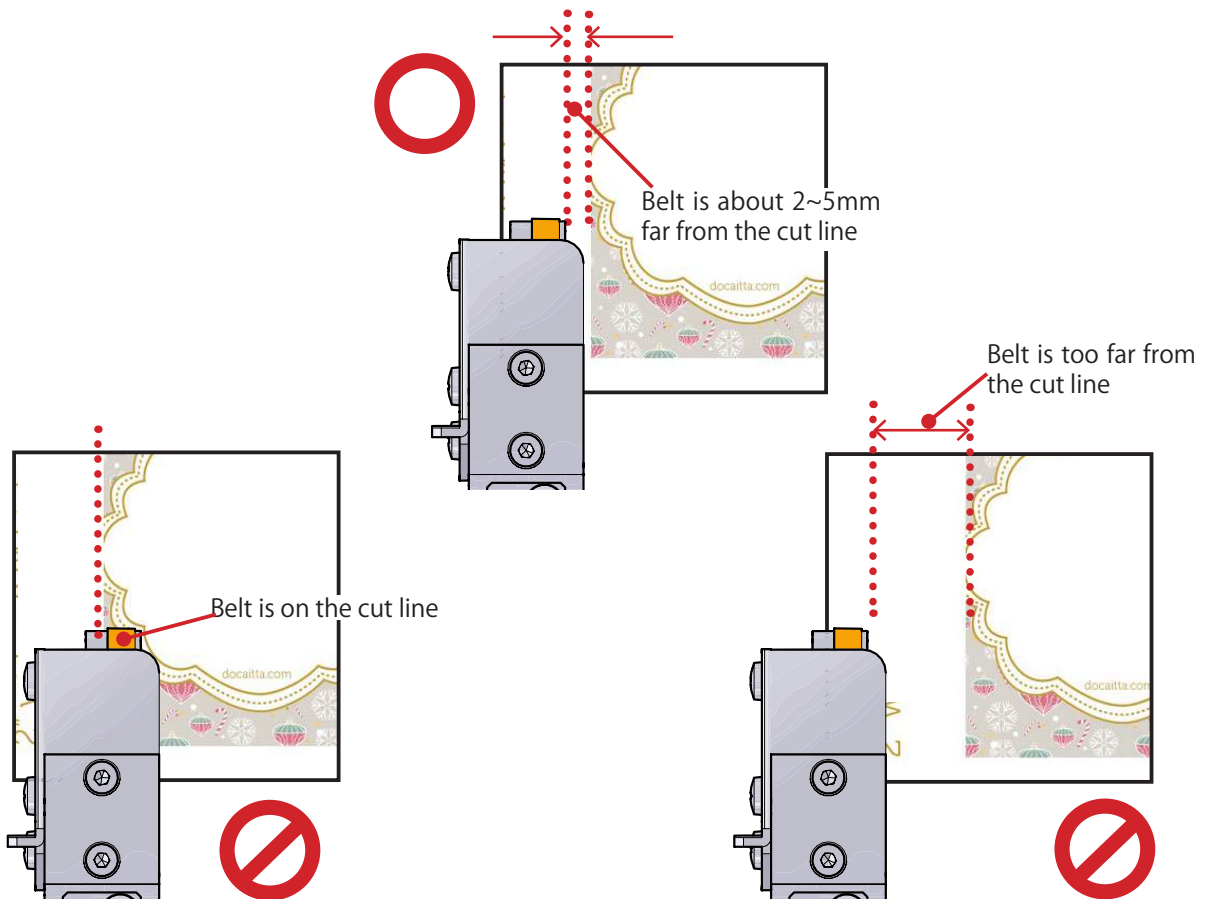

5) Set the Separator Nip Roll Unit

* Normally the Separator Nip Roller Unit is next to Separator Belt Unit on both sides.

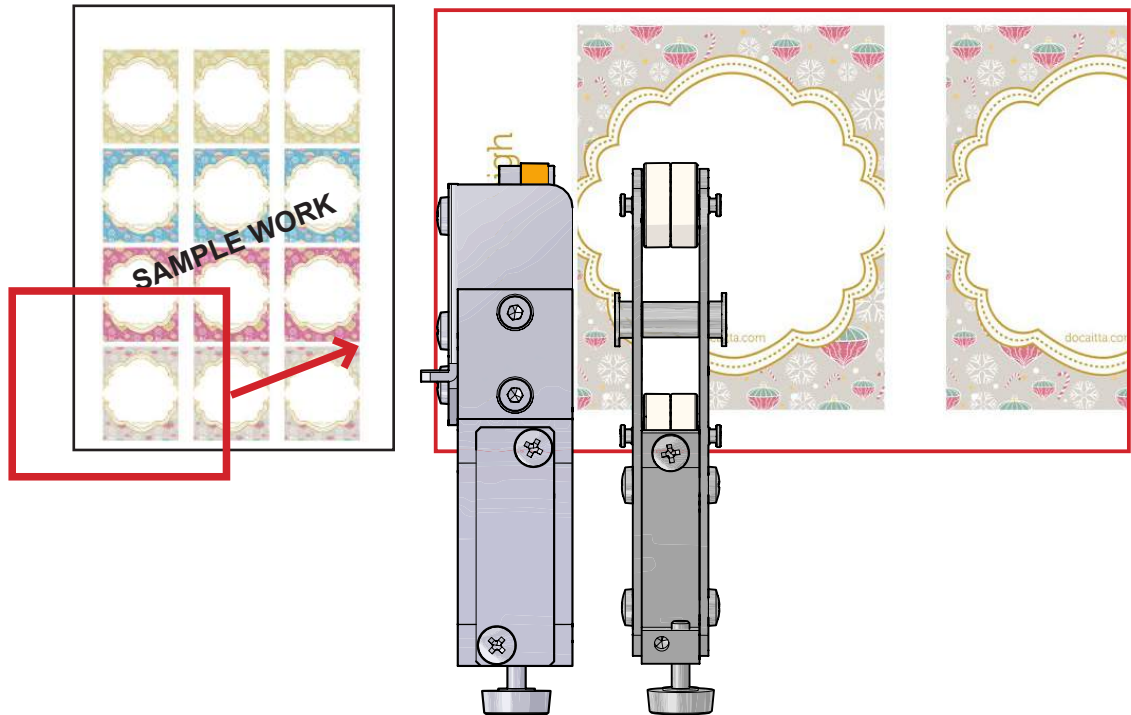

Possible to use on the center of cut pieces especially big 1UP design.

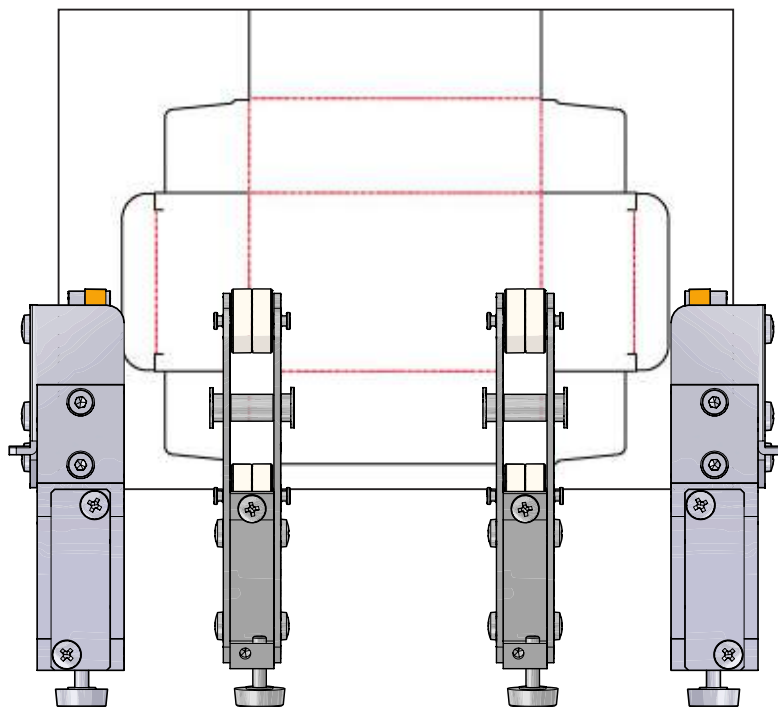

(3) Set the Separator Cassette on Separator section.

- 1) Set the Separator Cassette on Separator section and lock by "Lock Key" on both sides.
- 2) Close the Separator Unit and fix by "Separator Unit Fix Knob" on both sides.

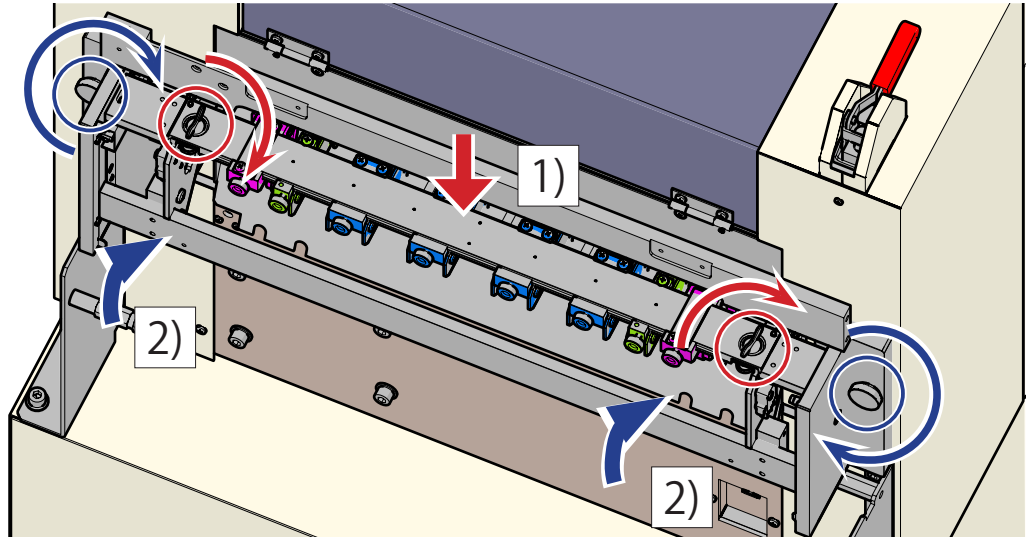

4-5 | Touch Panel Setting

* When input the numbers on every screen, push the "CLR" button and clear the current number.

Set the condition on the touch panel (input)

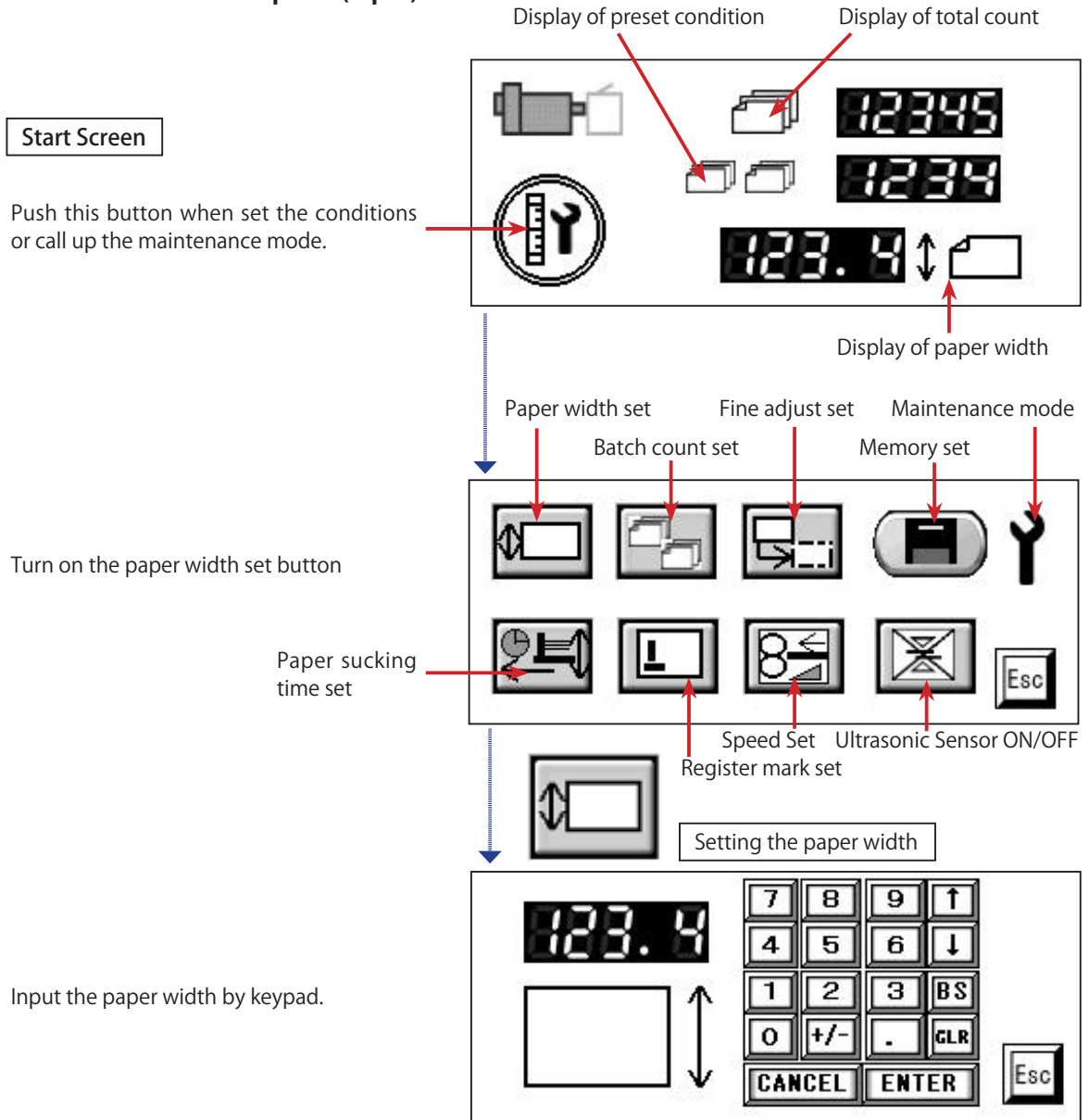



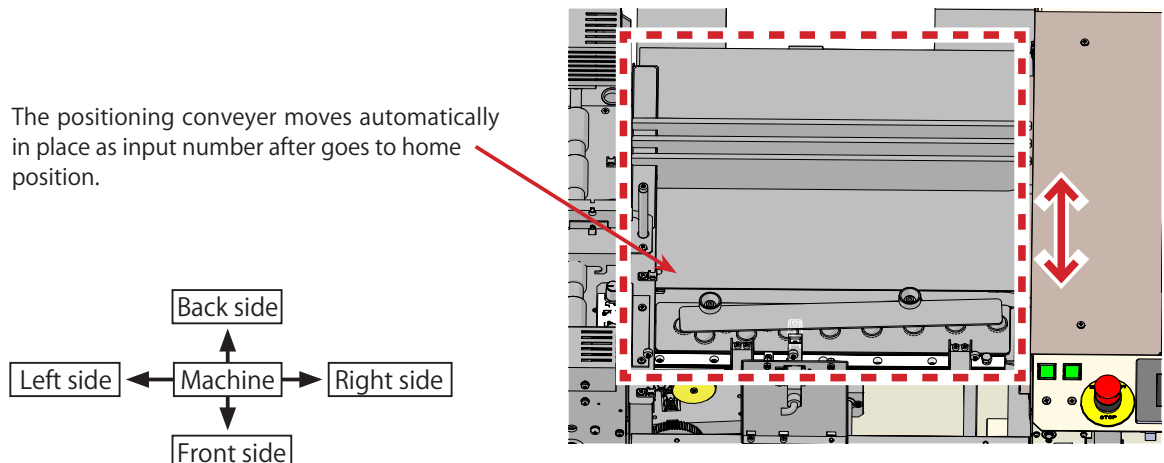

The positioning conveyer moves automatically in place as input number after goes to home position.



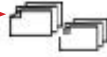



Setting preset and pause
(Lower display is total number)

Preset count →  ● 

Duration of pause
Auto start doesn't work when "0" set. →  ● 

Total count →  ●  

Push the preset count button and the right display comes up.
Input by keypad.
Push the [ENT] key after set.

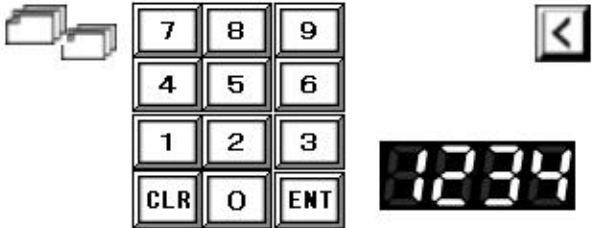

Push the pause count button and the right display comes up.
Input by keypad.
Push the [ENT] key after set.

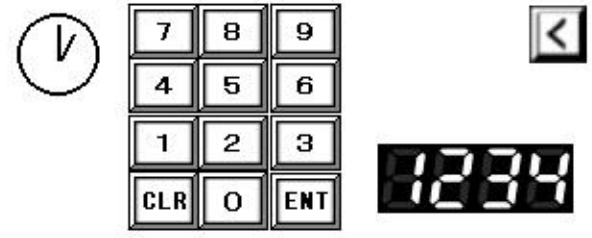

Push the total count button and the right display comes up.
Input by keypad.
Push the [CLR] key when reset the numbers.



Fine Adjustment

[X direction adjustment]

Max: +3mm

(If input more than +3, the paper may not be able to come to the right position, especially for bigger paper)

Min: -3mm

(If input less than -3, the paper edge which is coming from the feeder may hit the positioning guide.)

[Y direction adjustment]

Max: +25mm

Min: -5mm

* Depends on the paper size.

Push the fine adjustment button and the right display comes up.
Input by keypad.
Push the [ENT] key after set.



Fine adjustment of paper position

Adjustment number for shortways

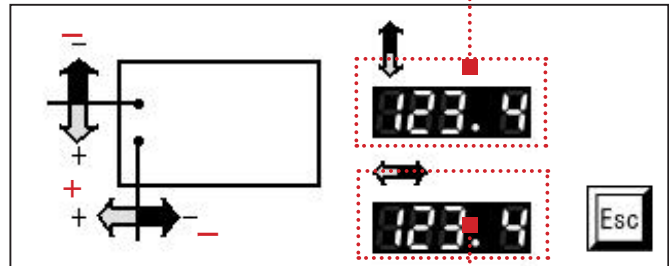

Adjustment number for longways

Input screen for X direction adjustment

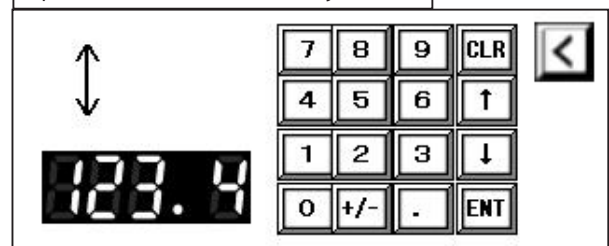

Input screen for Y direction adjustment

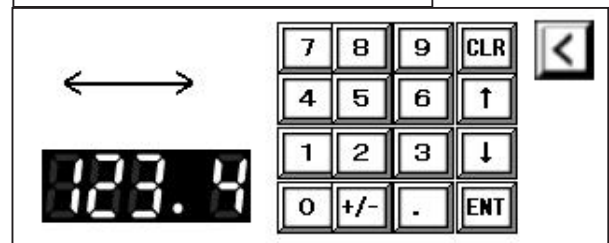

Memory Setting

1. The displayed number is current configuration.
2. If you'd like to memory the current configuration, choose the number where you'd like to input by keypad.
The memoried numbers will be displayed.
3. Push the [Memory] key and [ENT] key, the numbers will be replaced as you input.

Memory



Setting Memories

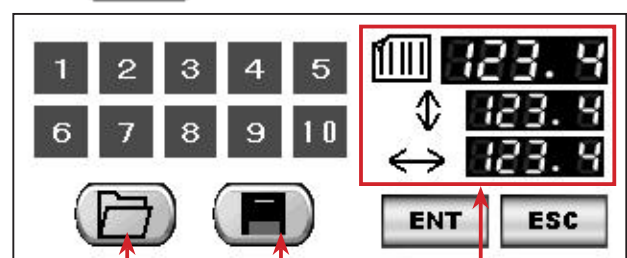

Job Folder

Memory

Current configuration

Feed Setting



Feed Setting

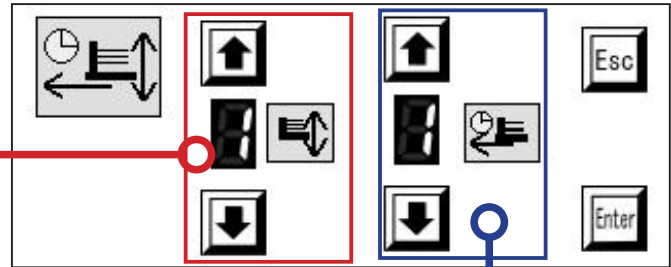

in-line Setting

- ※ For in-line use
Adjust the Feeder Table height depending on the connected equipment.
- ※ Need the in-line conveyer between this machine and connected product.

Air Suction timing

Adjust the air suction timing depending on the paper size.

- [Target] A4 size: "1"
A3 size: "2"~"3"
B3 size: "3"~"4"

Registration Function Set



Setting registration mark function

in-line Setting

- ※ For in-line use
Adjust the Feeder Table height depending on the connected equipment.
- ※ Need the in-line conveyer between this machine and connected product.

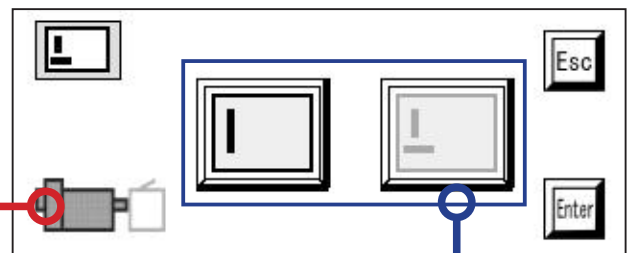

* Y-REG function
Reading Y axis registration only.

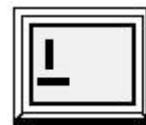

* XY-REG function
Reading both X and Y axis registration.

* Refer [4-2 | Reading Sensor Switch and Register Mark] for the detail.

Speed Set



Speed Set

Possible to adjust by 3 steps.

High speed: up to 4,000 sheets /h

Middle speed: up to 2,700 sheets /h

Low speed: up to 1,350 sheets /h

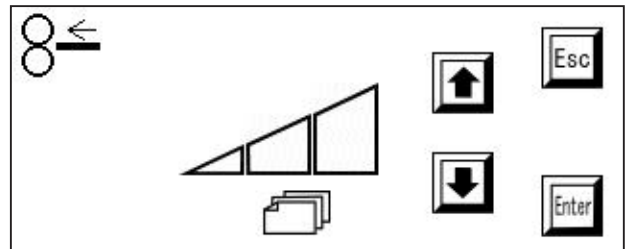

Ultrasonic Sensor Function



Ultrasonic Sensor ON/OFF

Possible to turn ON/OFF the Ultrasonic Sensor function.

* Please use this function only when using the special papers which cannot be detected by Ultrasonic Sensor.

※ Please ask to your dealer the detail before use this function.

Explanation of the display screen images

Operating screen



Error screen

1. Feeding sensor error
2. Double feeding sensor error
3. Magnet station sensor error 1
4. Magnet station sensor error 2

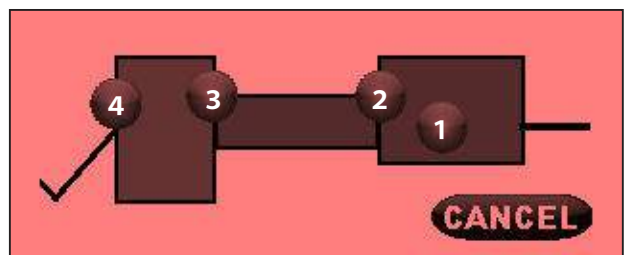

Cover error

- Check below when this error.
1. Positioning Conveyor cover
 2. Cylinder station cover
 3. Separator cover
 4. Separator unit attachment
 5. Emergency button

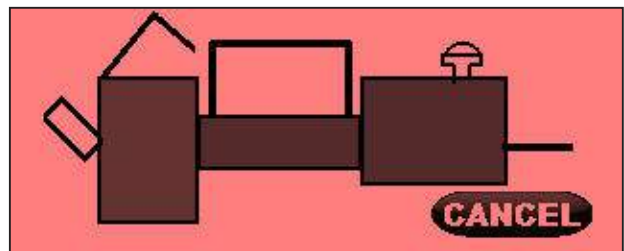

Calling screen



4-6 | Fine Adjustment Setting

* After set the Die Plate and conditions, push the start switch and process 1 sheet for test (Push the Stop switch right after 1 sheet is processed and make the machine stops.)

* There are 3 locations that you can adjust.

1. Skew adjustment (This process should be the 1st adjust than 2 other adjustments.)
2. Right and Left adjustment. (as stand in front of the operation side.)
3. Back and forward adjustment. (as stand in front of the operation side.)

(1) Skew Adjustment

Make the irregular position (red dash line) to the right position (black dash line).

* Skew adjustment should be a first line more than other fine adjustments.

———— Right position

- - - - Irregular position

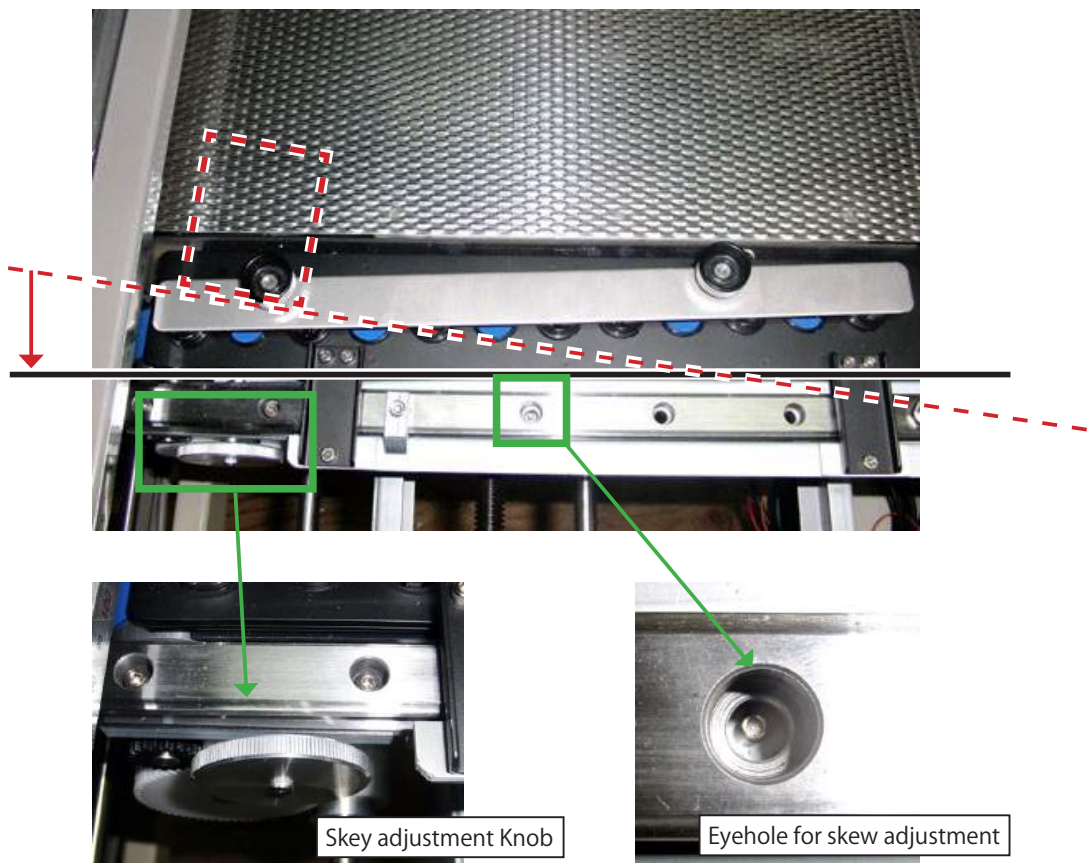
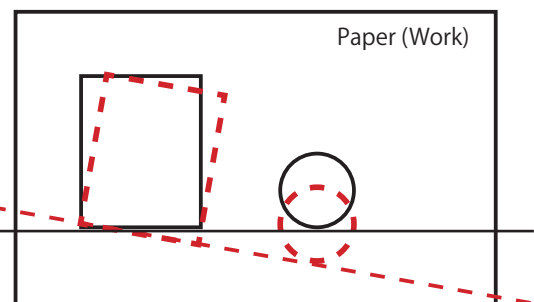

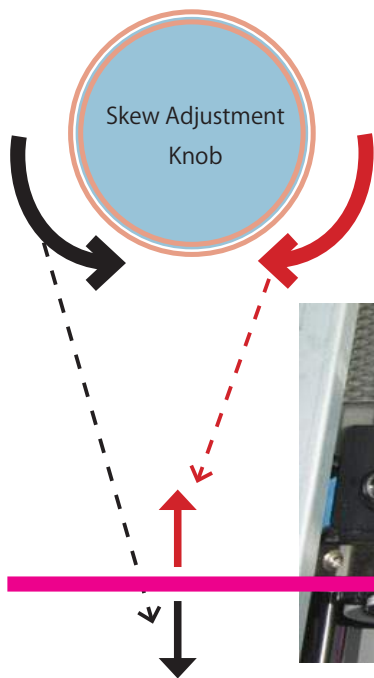

The Eyehole and the screw position in it tell the current position.

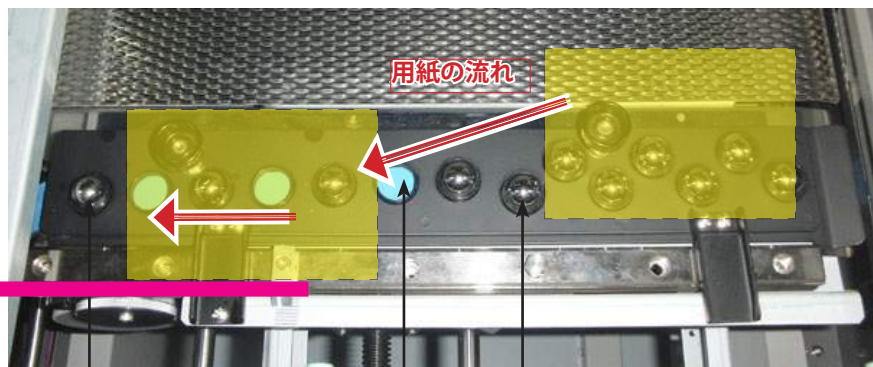

Ball Holder

Feeding Belt

Metal / Plastic Ball

(2) Forward and Backward direction Adjustment

* In case that 2mm irregular position

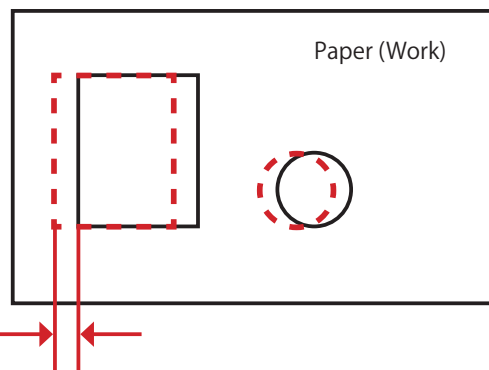
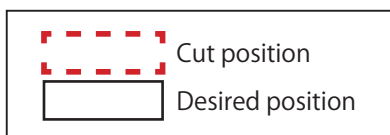

① Push [↔] and numbers area, and the following display comes up.

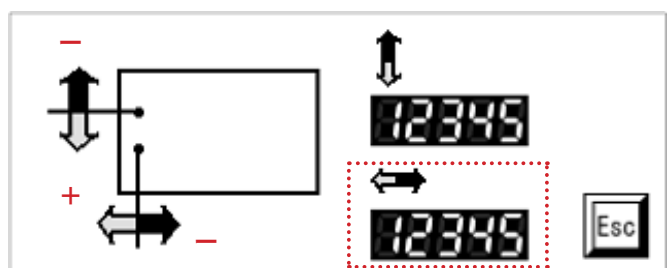

② Input "2.0" and push [ENT]

* When input minus figure,
1. Push the number that you input.

2. Push [+/-]

3. Push [ENT]

* When input plus figure,
just push the number that you input.

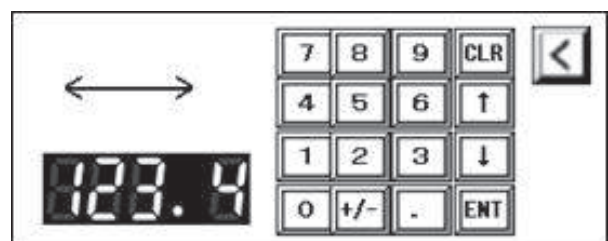

(3) Operation and Non-operation direction Adjustment

* In case that 2mm irregular position

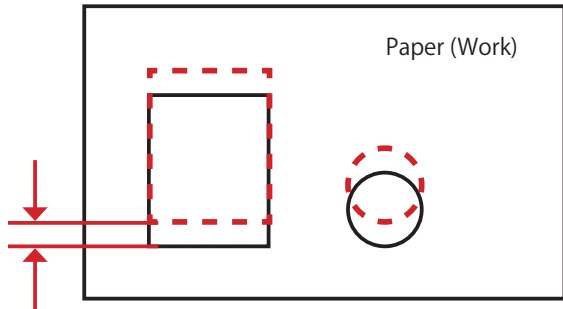
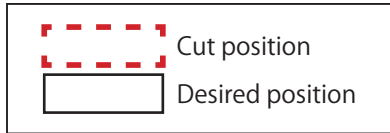

① Push [] and numbers area,
and the following display comes up.

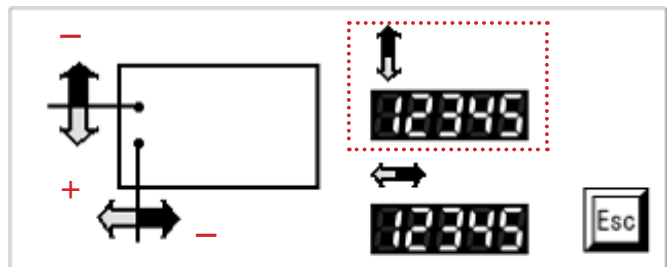

② Input "-" (minus) 2.0" and push [ENT]

- * When input minus figure,
 1. Push the number that you input.
 2. Push [+/-]
 3. Push [ENT]
- * When input plus figure,
just push the number that you input.

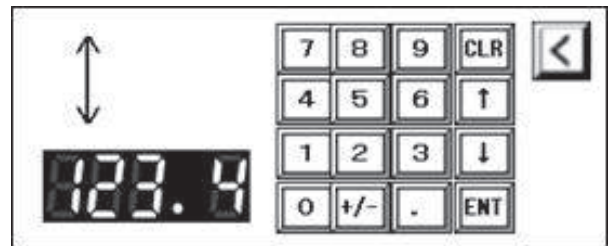

4-7 | Skill for better process

(1) Use "Micro-joint" for difficult handling paper

- When the cut paper jams often at separator section, make "**Micro-Joint**" on the Die Plate. This joint holds the cut pieces with the skeleton area (waste area) together and paper jam may be reduced. (especially synthetic papers and difficult handling paper)

The processed die will no longer be able to use with separator.
Make sure that the separator will not be used with the processed plate before processing.

[Micro-Joint]

Make the tiny damage on the blade.
The cut pieces connect to the waste space area by it,
and will be better discharge.

Micro-Joint can be made by the Die Plate Maker.
However the customer also can make it especially when
the Micro-Joint should be in the appropriate position.

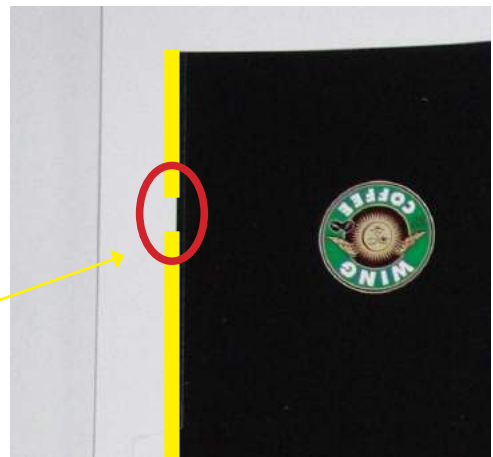
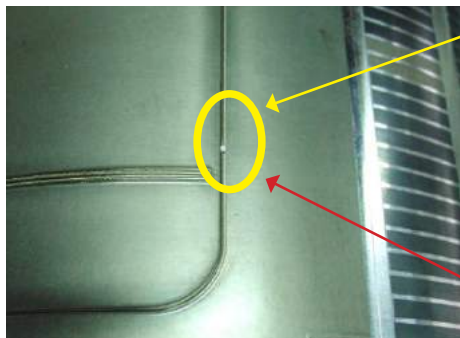

Make the tiny damage on the blade by the triangular file.



(2) Use "Fluorine separate spray" for better separation from the Die Plate

- When the jam happened on the Magnet Cylinder area or cannot be discharged smoothly because the cut pieces dig into between the blades.

As the right figure, the Work cannot be come out smoothly.
(The condition that the cut pieces stay into between the blades)

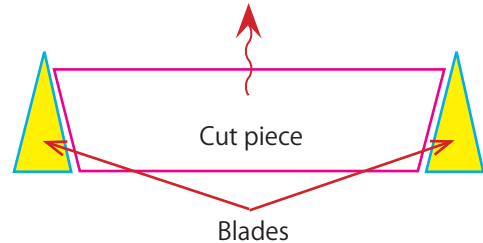

+ When the Work cannot be come out smoothly.

Spray on the blades' area with the silicon or fluorine series, and the cut pieces can be come out smoothly.
Do not spray too much. The Work gets dirty.

Make sure to remove the Die Plate from the Magnetic Cylinder when spray.

This spray material is not good for rubber material especially nip rollers.

Silicon or fluorine series spray (reference)



(3) Use "Sponge" for better separation from the Die Plate

- When the jam happened on the Magnet Cylinder area or cannot be discharged smoothly because the cut pieces dig into between the blades.

Sponge helps to push the cut pieces from Die Plate.

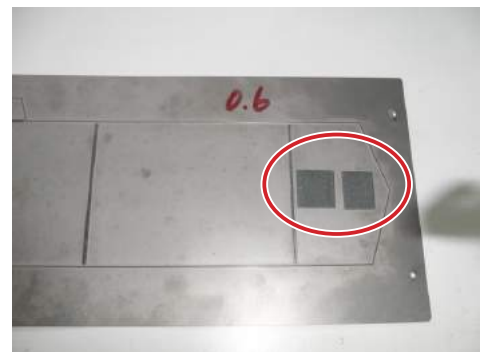
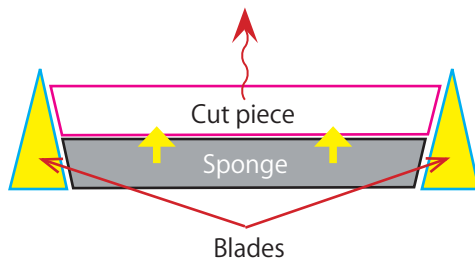

+ Make sure the below points when use sponge on Die Plate.

- * Make sure that the sponge is not in front of the first blade position.
- * Cut quality may change depending on the sponge loations.
- * Cut pieces may get damage depending on sponge material.

(4) Use "Sponge" or "Dammy Blades" for slipping problem

■ When the cut pieces becomes shorter. (Cut sizes are variable and not stable.)

* The cut pieces will be shorter if the paper slips on the blade.

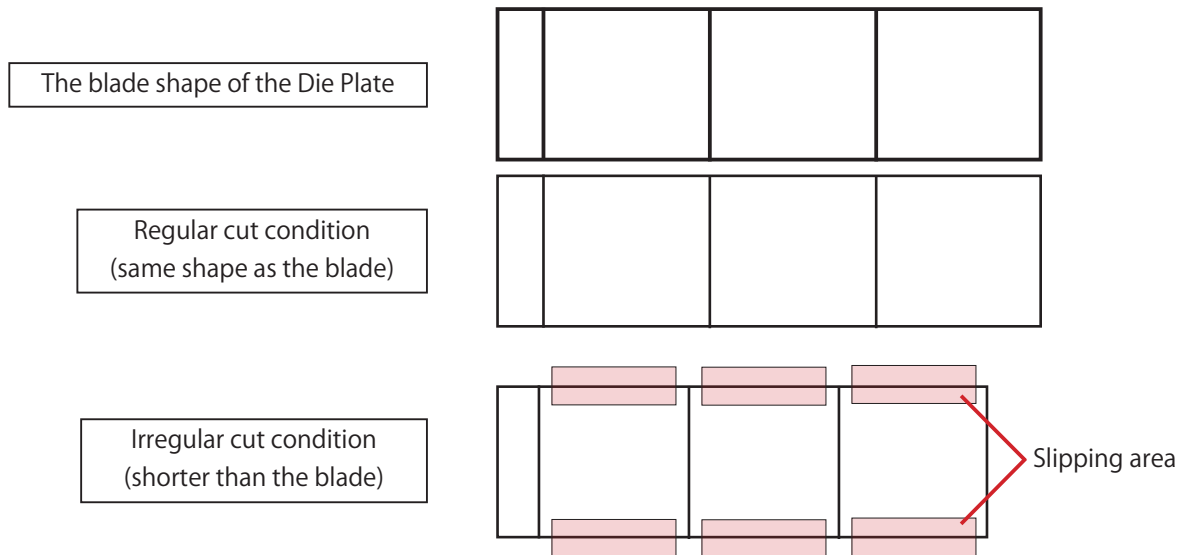

■ When the cut pieces becomes shorter. (Cut sizes are variable and not stable.)

* The paper slips at the "no blade area".

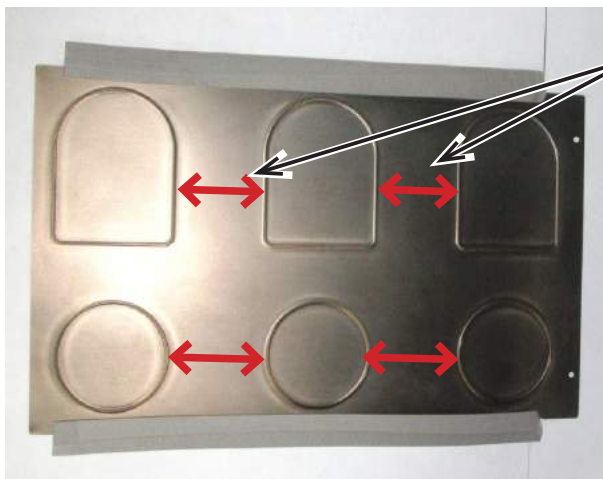

Area that the paper slips:

- + There is no blade.
- + The blades are all parallel with paper feeding direction.

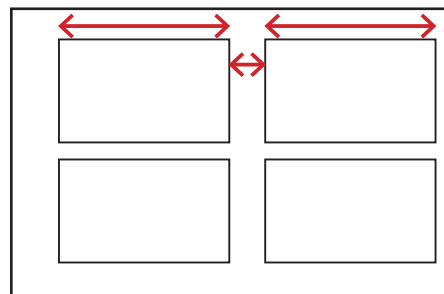

Sponge arrange: Put the sponge (cushion material) on the Die Plate and prevent the paper slipping.

4mm thickness cushion
(Door-Stop-Tape
[made by Cemedine Co., Ltd])
Thickness: 4mm / Width:15mm
* When the label papers or
thin papers are handled.

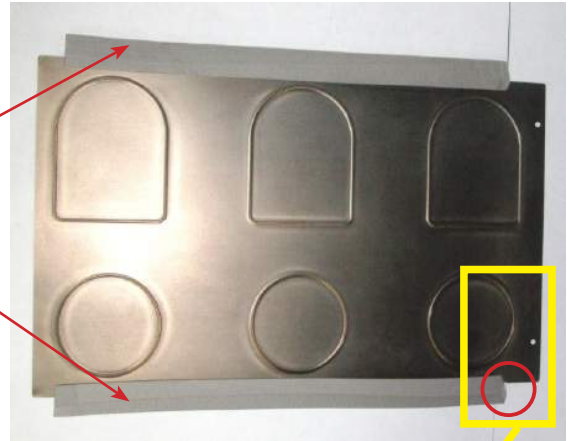

Slice the edge off as the cushion edge
doesn't hook into the Backer Roller face.

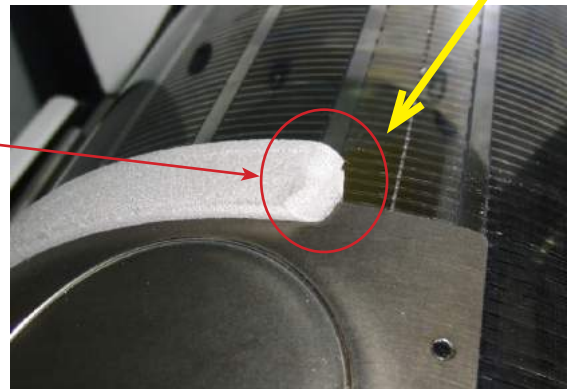

2mm thickness cushion
* When the middle thickness
papers are handled.



Make sure that the cushion materials are not forward than the first blade on the Die Plate, or the cushion hits the paper face faster than the first blade and quality becomes low.

Dammy Blade arrange: Make the "Dammy blades" on the Die Plate and prevent the paper slipping. (Please contact with the die manufacturer.)

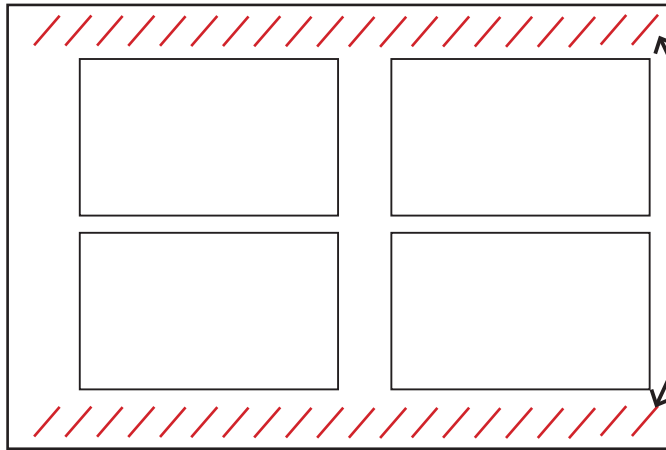

There are many kinds of "Waste blade" shapes. Please ask the detail to the plate maker.

5. Aftercare

- ☆ Unplug the power cord before the after care operation.
- ☆ Wear gloves and protective eyeglasses when cleaning the cylinder.
- + Store in a cool and dry place and close a cover when you don't use for a while.
- + Make sure that there is no foreign material on the Magnet Cylinder and the Backer Roller .
(Wipe carefully with a dried clothdust.)

* This parts are very expensive, so the sufficient maintenance is a must.



Magnet Cylinder: Oil (Light type)

Backer Roller: Alcohol

* Clean up by a clothdust impregnated with alcohol only on the center area which is the shaded portion.
Do not clean with alcohol on the sides or the magnet cylinder gets rusted.

Not only the Magnet Cylinder and the Backer Roller, but also the Die Plate get damage if the foreign materials stay. Please wipe with a dried clothdust first, and coat by a clothdust impregnated with a lighter oil for rust prevention, after use.

*** Remove the Die Plate after use or the Magnet Cylinder gets rusted.**

Wiping by a dried clothdust and lighter oil is a must after removed the Die Plate. (for rust prevention)

- + Lubricate the Magnet Cylinder and Backer Roller felt regularly. (Important: once a week)

Open the Rear Cover as the above picture, and lubricate the felt part under Backer Roller.

In case when the Rear Cover is closed, you can also lubricate from this hole.

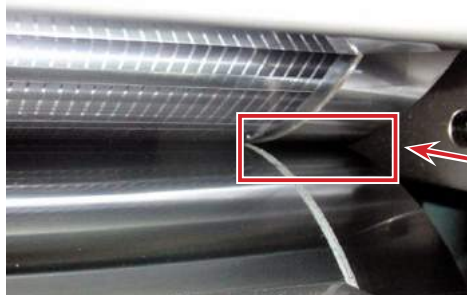
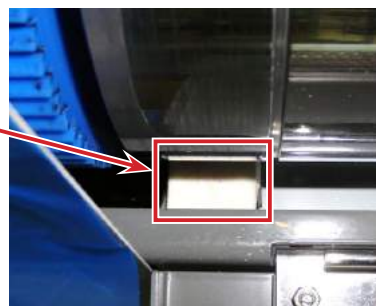

Lubricate between the Magnet Cylinder and the Backer Roller.
Do not spray too much or papers get dirt.



6. Troubleshooting

■ Feeding

Phenomenon	Cause	Action
Equipment does not operate. (Double beep)	The covers are not set.	Set the covers as right position.
	The interlock switches are not working.	Make sure the locations of interlock switch and switch works. If the switch doesn't work, change it. (Reference P.3)
	The Emergency Button is pushed.	Clear the emergency button.
Paper is not fedded.	Paper Separator Rubbers are too high position.	Adjust the Paper Separator Rubbers in the right position.
	The Feeder Table does not lift up in regular position.	Make sure that the Detection Bar behavior.
	Papers are not separated well.	Separate the papers well. Anti-Static Jogger is effective. (UJ-600AS)
Feeding is not smoothly.	Paper curl is too strong.	Let the papers be flat.
	Papers are not separated well.	Separate the papers well. Anti-Static Jogger is effective. (UJ-600AS)
	Air suction timing is not correct.	Adjust the air suction timing depending on paper size. (ref. P.42/Feed Setting)
Double feeding is happened.	Paper Separator Rubbers are too low position.	Adjust the Paper Separator Rubbers in the right position.
	Papers are not separated well.	Separate the papers well. Anti-Static Jogger is effective. (UJ-600AS)
	Paper height detection is too late. (Detection Bar is too high)	Adjust the Detection Bar in the right position.
	Air suction time is too long. (especially for short sized paper)	Set suitable time for the paper size. (ref. P.42/Feed Setting)
Paper stops at the entrance of the Positioning Conveyor.	Paper Guides of the Feeder are too tight.	Create a gap about 2mm between the papers and Guides.
	Setting of the Positioning Conveyor is not appropriate.	Reset the setting of the Positioning Conveyor.
	Air suction time is too short. (especially for long sized paper)	Set suitable time for the paper size. (ref. P.42/Feed Setting)
	Fine adjustment of the Positioning Conveyor is too minus value.	Make the Work design and the Die Plate in the center position. If the fine adjustment is too big, arrange the position by the Die Plate setting.

Phenomenon	Cause	Action
Paper stops in the middle of the Positioning Conveyer.	Paper curl is too strong.	Let the papers be flat and use Deflection Plates for paper curl.
Adjustment of the paper position cannot work.	Covers are opened while you set the positions.	Close the cover and set again.
	The Emergency Stop Button is pushed.	Clear the emergency button and set again.
Paper jam	Using "difficult handling" paper.	Decrease the process speed. (ref. P.43/ Speed Set)
The machine stops due to a double-feeding error even though the two-sheet insertion has not occurred.	This machine reading the layers by Ultrasonic sensor. Therefore, double feeding error happens, if the paper is special paper (some layers even if one sheet).	Turn off the "Ultrasonic Sensor Function" on touch panel. (ref. P.43/ Ultrasonic Sensor function) * Please ask to your dealer the detail before use this function.

* Push and ON the Emergency Stop Button when clear a jam.

■ Die Station

Phenomenon	Cause	Action
Work cannot be cut completely.	Magnet Cylinder is not locked.	Lock the Magnet Cylinder to the Backer Roller by the Cylinder Lock Lever on both sides. ATTENTION: <u>Lock position: Turn the lever at separator direction.</u> <u>Unlock position: Turn the lever at feeder direction.</u>
	Die Plate is not set in the right position.	Set the Die Plate in the right position. (Make sure that the 2 holes of the plate are not upon the pins of the Magnet Cylinder by the loupe)
	Die Plate is warn out.	Maintenance and repair the Die Plate.
	Blade of the Die Plate is too low.	The Die Plate problem. Contact to the plate manufacturer.

■ Die Station

Phenomenon	Cause	Action
Cutting quality is not good.	Adjustment is not appropriate.	Reset the paper width and fine adjustment correctly. Make sure the setting value is in spec.
	Adjustment of the Positioning Conveyor is not appropriate.	Reset the paper width and fine adjustment correctly. Adjust the position of the Positioning Conveyor again.
	Die Plate is not set in the right position.	Set the Die Plate in the right position. (Make sure that the 2 holes of the plate are not upon the pins of the Magnet Cylinder by the loupe)
	Press Roller gets dirty.	Clean the Press Roller with alcohol.
Incapable of fine adjustment.	Be outside of the fine adjustment control.	Impossible to adjust over plus-minus 5mm. Possible to adjust by the Die Plate position.
	Die Plate is not set in the right position.	Set the Die Plate in the right position. (Make sure that the 2 holes of the plate are not upon the pins of the Magnet Cylinder by the loupe)
	Work design and Die Plate are not in the center position.	Reset the Die Plate position and adjust again.
Incapable of skew adjustment.	Die Plate is not set in the right position. Be outside of the skew adjustment control.	If the skew adjustment is impossible to adjust any more, reset the Die Plate position and adjust again. (Make sure that the Work design is not skew, first)
	Metal/prastic balls of Positioning Conveyor are not appropriate position.	When the thin or light papers are handled, reduce the metal balls number. When the thick or heavy papers are handled, add the metal balls number.
	Print image is too skewed and out of spec for skewing degree.	Impossible to adjust by this machine.
Half cutting doesn't work	Magnetic Cylinder is not locked.	Lock the Magnet Cylinder to the Backer Roller by the Cylinder Lock Lever on both sides. ATTENTION: <u>Lock position: Turn the lever at separator direction.</u> <u>Unlock position: Turn the lever at feeder direction.</u>
	Blade height is wrong for paper.	This is a plate problem. Contact with the die plate maker.

*** Wear gloves when operate the die plate.**

■ Discharge

Phenomenon	Cause	Action
Paper jam	Separator parts are not at the correct position at Separator section.	Make the correct positions for die design.
	Micro-Joint of Work is not appropriate position.	Rethink and make the Micro-Joint in the appropriate position.
	Paper type is special handling paper.	1) Slow down the process speed. (ref. P.43) 2) Put the sponge on the die plate. (ref. P.49)

■ Others

Phenomenon	Action
Machine was operated without Die Plate.	Push "Emergency Stop Button". Feeder stops after two sheets were fed. Magnet Cylinder keeps turning at this time. Set the die plate and operate again.
Double feeding is happened and Magnet Cylinder is locked.	Loosen up the Docking Handles and pull out the papers.
Machine is malfunctioning.	Restart the machine.

7. Specifications

Type	Rotary Die Cutter	
Model number	UD-310	
Processing method	Pressed by Magnet Cylinder / Cut by Die Plate	
Paper size	Max: B3 (364 x 515mm) Min : A4 (210 x 297mm)	
Paper thickness	Max: 0.4 mm Min : 0.22 mm	
Speed	Up to 4,000 sheets /h (Speed adjustable: 4,000 / 2700 / 1350 sheet /h)	
Work supply system	Air Suction Feeding / Registration reading	
Load capacity	220mm	
Transfer	Positioning Conveyer	
Minimum cut size with separator	40 mm (W) x 50.8 mm (L)	
Minimum side space with separator	15 mm on both sides	
Minimum space between cut pieces with separator	10mm	
Outer dimension	Main Body: 2,060 (W) x 690 (D) 1,190 (H) mm with Conveyer: 3,226 (W) x 690 (D) x 1,190 (H) mm	
Weight	400kg	
Electrical source	100V 90~110V 50/60Hz (Japan) 115V 105~125V 60Hz (North of America) 230V 210~245V 50Hz (CE)	
Usage environment	IPX0(zero) [Non protected for water: Non use at the place near the water.] At an altitude below 1,000 meters Non use at the place in dust. 5 degrees C ~ 35 degrees C 20%RH ~ 70%RH	
Storage environment	-10 degrees C ~ 50 degrees C 10%RH ~ 90%RH	
Noise level	74 dB	

