

DocuCutterCC-330

Operational Manual



Before operating the machine, read this manual. Follow all safety precautions.

Table of Contents

SAFETY PRECAUTIONS	3
Introduction	4
Specifications	4
Accessories	4
Major Components and Assemblies	5
Control Panel	7
Installation	8
Setting Up Procedure	9
The Job selection	11
Registration Mark Position	15
Selecting a job.....	15
Batch Count function.....	16
User Define Job.....	16
Turbo and normal Mode	17
Paper weight.....	17
Reset Counter	18
Clear Jam	18
Troubleshooting	19
Optional Slitter Cassette.....	19
Optional Conveyor.....	20

SAFETY PRECAUTIONS

Always observe the cautions and warnings given below to prevent personal injury or property damage.

⚠ WARNING:



Always pull the power supply plug out of its outlet before removing jammed paper.



Do not use supply voltage other than the specified voltage.



Do not insert pins, wire or other foreign objects into the machine. Do not allow any liquid to get into the machine through its openings or gaps in its structure.



Do not modify the machine. Do not remove any of the covers from the machine..



Keep this unit and the power cord away from heaters and heater vents. Excessive heat could melt the cover or power cord covering, and result in a fire or an electrical shock.

⚠ CAUTION:



Do not put fingers inside during operation.
Keep away long hair, ties, jewelry and loose clothing.



Install this unit on a level, stable stand or floor, with sufficient space around it.



Do not install this unit in a location where there is excessive humidity or where contact with water is possible.



Disconnect the power plug from the power outlet before attempting to move this unit. Failure to do so could result in power cord damage, a fire or an electrical shock.

INTRODUCTION



The Docucutter CC-330 is designed to simplify business card, photo and post card cutting in letter size which printed by digital press, color laser printer or inkjet image printer in one pass.

SPECIFICATIONS

Paper Size	LT, LG, LD, 12 x 18 and 13 x 19
Paper Weight	120 ~ 350 gsm
Feeder Capacity	120 sheets (300gsm)
Receiving Tray	250 business Card x 3
Speed	Up to 240 business cards/min Based on 55x90mm in A3
Accuracy	± 0.2 mm
Dimension -- With Conveyor ■ W/O Conveyor	98.5 X 53.5 X 101.5CM (38.8x21.1 x 40") 48.5 X 53.5 X 101.5CM (19.1 x 21.1 x 40")
Net Weight –With Conveyor ■ W/O Conveyor	70.8Kgs (156 lbs) 61.2Kgs (135 lbs)
Power	110/220V Selectable, 50/60Hz, 1.2A

ACCESSORIES

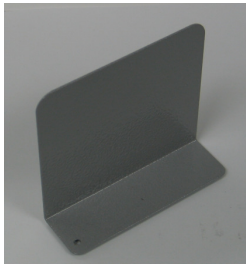
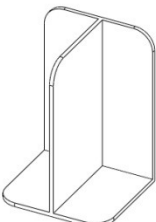
Make sure all accessories provided with the machine.

		
Power Cord	"L" Stacking Guide X 4	Center Stacking Guides X 2
		
Stacking Tray	Operation Manual	

MAJOR COMPONENTS AND ASSEMBLIES

1	Power Switch
2	Control Panel
3	Extended Tray
4	Top Cover
5	Waste Compartment Door
6	Machine Stand





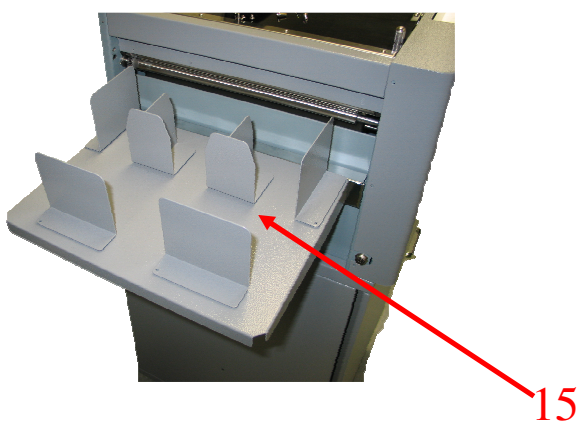
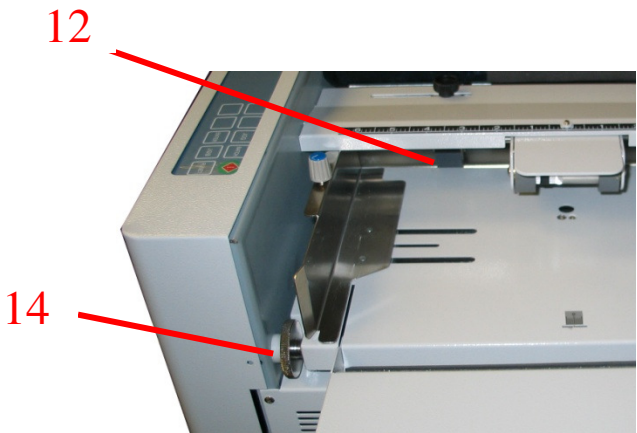
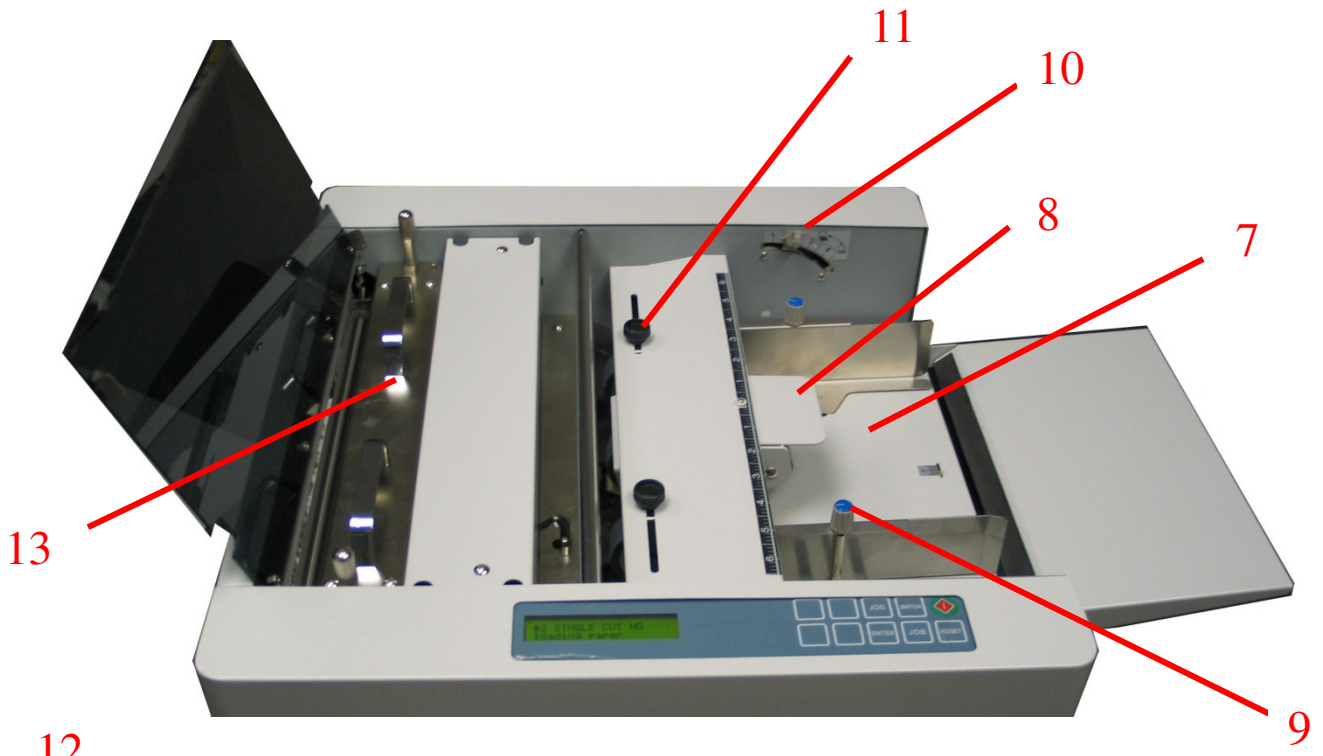



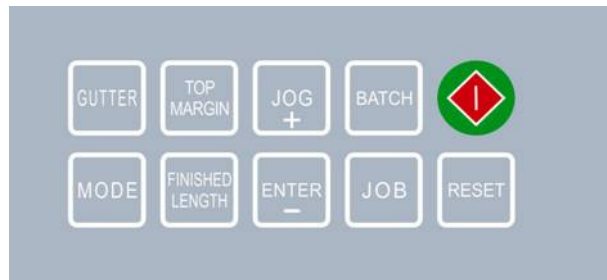

7	Stack Tray
8	Auxiliary Roller
9	Side Guide Adjustment Knob
10	Feed Tray Pressure Adjustment
11	Feed Rollers Adjustment Knob
12	Feed Rollers
13	Slitter Cassette
14	Slitting Registration Adjustment
15	Stacking Guides



CONTROL PANEL



Keys	Function
	<ul style="list-style-type: none"> •Start and Stop the cutter
	<ul style="list-style-type: none"> •Change job •Toggle between “Normal Mode” and “Turbo Mode” (Paper Weight Setting Mode)
	<ul style="list-style-type: none"> •Select batch count •Pre-feed (Mark Reader Calibration Mode)
	<ul style="list-style-type: none"> •Jog forward •Increment settings by 0.1 mm when press.
	<ul style="list-style-type: none"> •Confirm job and batch count setting. •Decrement settings by 0.1mm when press (Mark Reader Calibration Mode). •Jog backward •Reset counter (use with “RESET” button simultaneously)
	<ul style="list-style-type: none"> •Save settings •Hold (4s) paper weight setting mode •Reset counter (use with “ENTER” Button simultaneously)
	<ul style="list-style-type: none"> •Enter program mode •Change paper weight
	<ul style="list-style-type: none"> •Set top margin
	<ul style="list-style-type: none"> •Set finished length

INSTALLATION

1. CUTTER INSTALLATION

Stands

Place the machine on the stands. Make sure to align the pins on the stand to the holes on the base plate of the machine. The door of the stands should face the operator side.

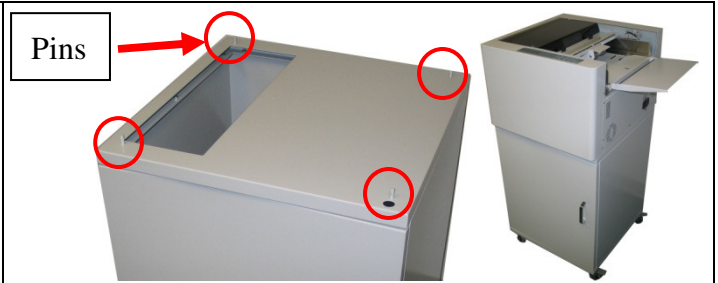

Safety Switch

- **Remove the front cover.**
- **Open the door in the stand and run the wires up to the cutter.**
- **Connect the wires to the terminal block.**

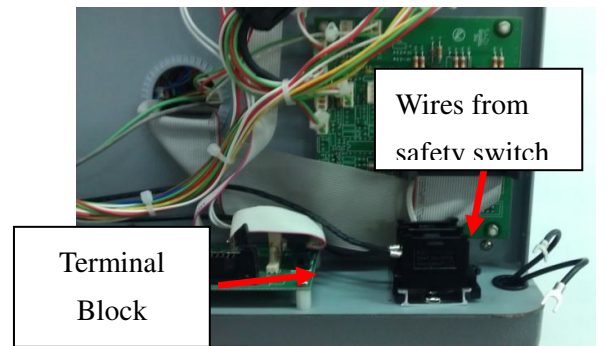

Stack Tray

Attach the stack tray to the machine with the two screws provided.

Place "L" stacking guide and center staking guide as shown

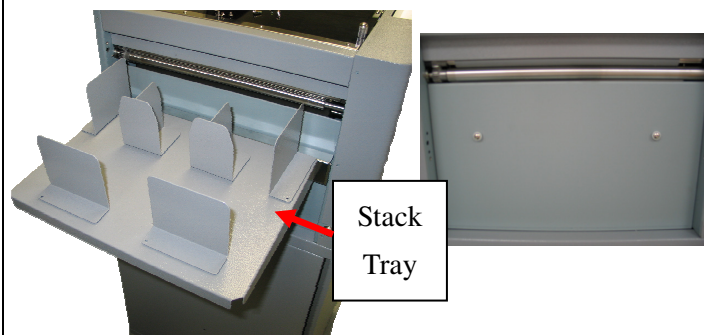



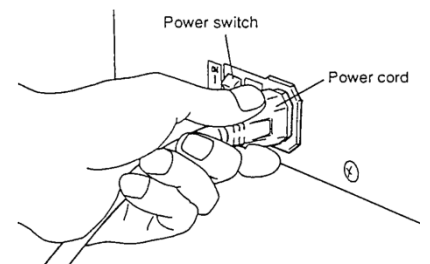

Power Cord

Use caution when plugging in power cord. Plug power cord to the machine and plug the other end into the wall outlet.

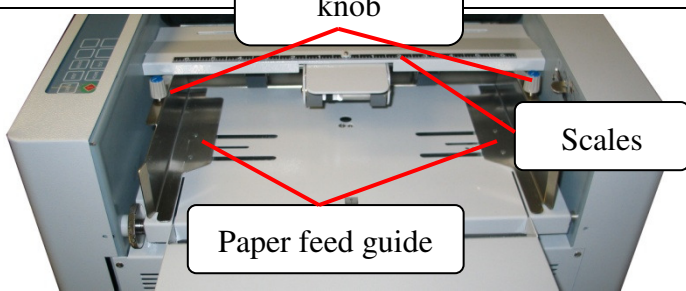

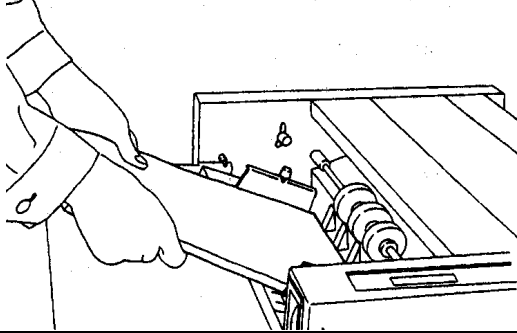
SETTING UP PROCEDURE

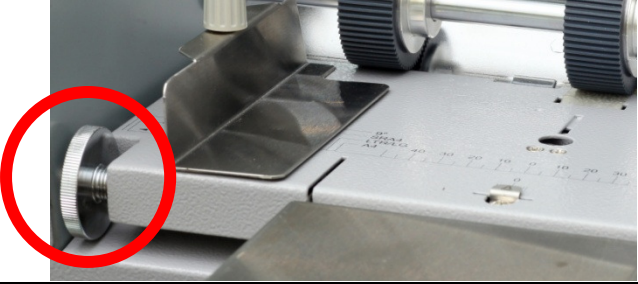
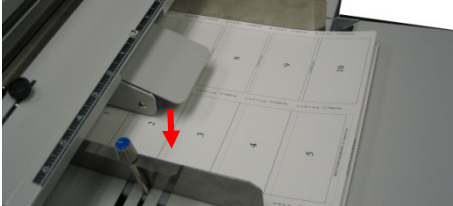
<p>1</p>	<p>To set the width of paper, loosen thumbscrew knob on the side guide and slide to position. Use scales as reference point.</p>	
<p>2</p>	<p>Fan paper before loading. This will reduce static and toner adhesion due to printing. For best result, the paper stack should be flat.</p>	
<p>3</p>	<p>Push the feed tray down and load the paper. Readjust paper guide if needed.</p>	
<p>4</p>	<p>Adjust tray pressure. For thinner paper, the number should be higher. For heavier paper the number should be lower.</p>	
<p>5</p>	<p>Use slitter registration adjustment knob to compensate for printing registration. The knob will allow ± 2mm of adjustment.</p>	
<p>6</p>	<p>Auxiliary roller is for hard to feed paper. To use auxiliary roller, laid the rollers down onto the paper.</p>	

7

Adjust feed rollers so they are about 0.5" away from the edge on each side of the paper.

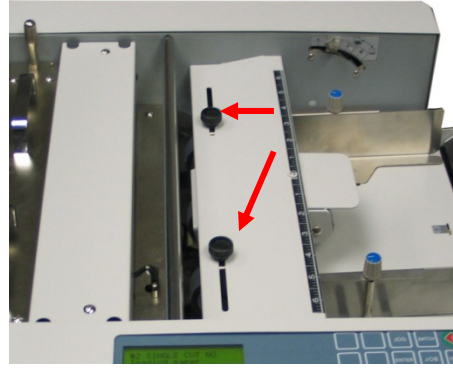

THE JOB SELECTION

DocuCutter CC-330 offers 7 different types predefined job selection from #01 to # 07 and 6 programmable job #08 to #13. The standard cassette has a slit size of 3.5" x 3 rows for business card. Optional cassettes are available. See below to select the proper slitter and program for your application.

Slitters

Slitters	Slit Size	Gutter Size	Number of rows	Default Size
Standard Slitter	3.5"	0.25"	3	3.5"
Optional Slitter A	8.5" to 11"	None	1	11"
Optional Slitter B	4" to 6"	0.25"	2	6"

Applications

Layouts	Job #	Applications	Display	Paper Size	Finished Size	Layouts	Gutter	Margin	Slitters
A	1	Full Bleed Business Cards	Business Card	12"X18"	2" x3.5"	24 up	0.2 in (5.08 mm)	0.35" (8.9 mm)	Standard Slitter
B	2	Business card	Business Card	12"X17"	2" x3.5"	24 up	None	0.75" (19.1 mm)	Standard Slitter
C	3	Brochure	Brochure	12"X18"	8.5" x 11"	2 up	0.25 in (6.35 mm)	0.5" (12.7 mm)	Option Slitter A (11 in.)
D		Insert/Greeting Cards		12"X18"	3.5" x 8.5"	6 up	0.25 in (6.35 mm)	0.5" (12.7 mm)	Standard Slitter
E	4	Photo	Photo	12"X18"	8" x 10"	2 up	1.25 in (31.75 mm)	0.5" (12.7 mm)	Option Slitter A (10 in.)
F		Insert/Greeting Cards		12"X18"	3.5" x 8"	6 up	1.25 in (31.75 mm)	0.5" (12.7 mm)	Standard Slitter
G	5	Postcard	Postcard	12"X18"	5.5" x 8.5"	3 up	0.375 in (9.525 mm)	0.5" (12.7 mm)	Option Slitter A (8.5 in.)
H	6	Postcard	Postcard	12"X18"	5" x 7"	4 up	3.25 in (82.55 mm)	0.5" (12.7 mm)	Option Slitter B (5 in.)
I	7	Postcard/Photo	Postcard	13"X19"	4" x 6"	8 up	0.5 in (12.7 mm)	0.5" (12.7 mm)	Option Slitter B (6 in.)
J	8-13 Custom Program	Postcard	(Program)	12"x18"	3.5"x5"	9 up	0.875 in (22.2 mm)	1.00" (25.4 mm)	Standard Slitter
K		Brochure		12"X18"	11" x 17"	1 up	None	0.75" (19.1 mm)	Option Slitter A (11 in.)
L		Postcard		13"X19"	6" x 9"	4 up	0.25 in (6.35 mm)	0.5" (12.7 mm)	Option Slitter B (6 in.)

Job Layout

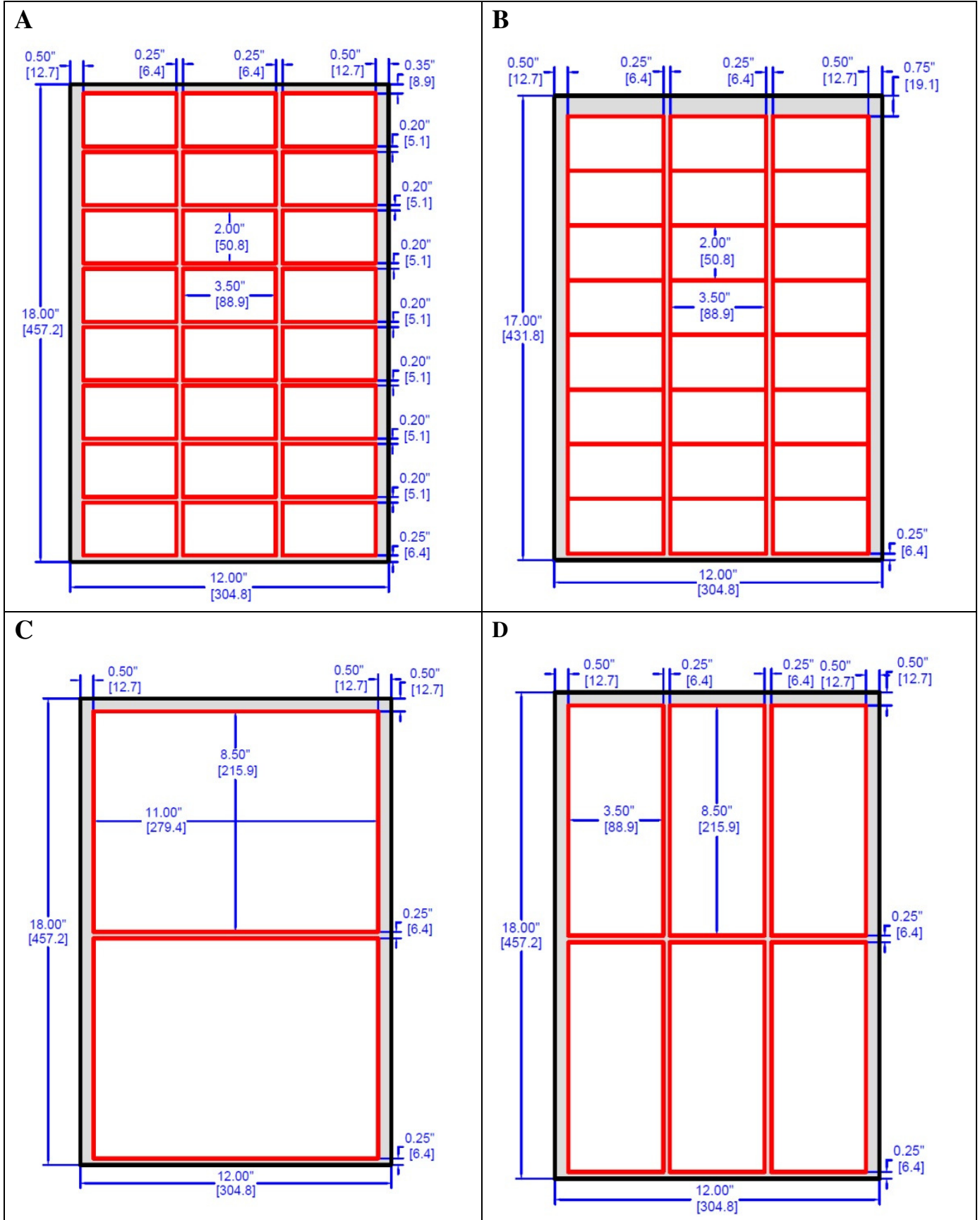

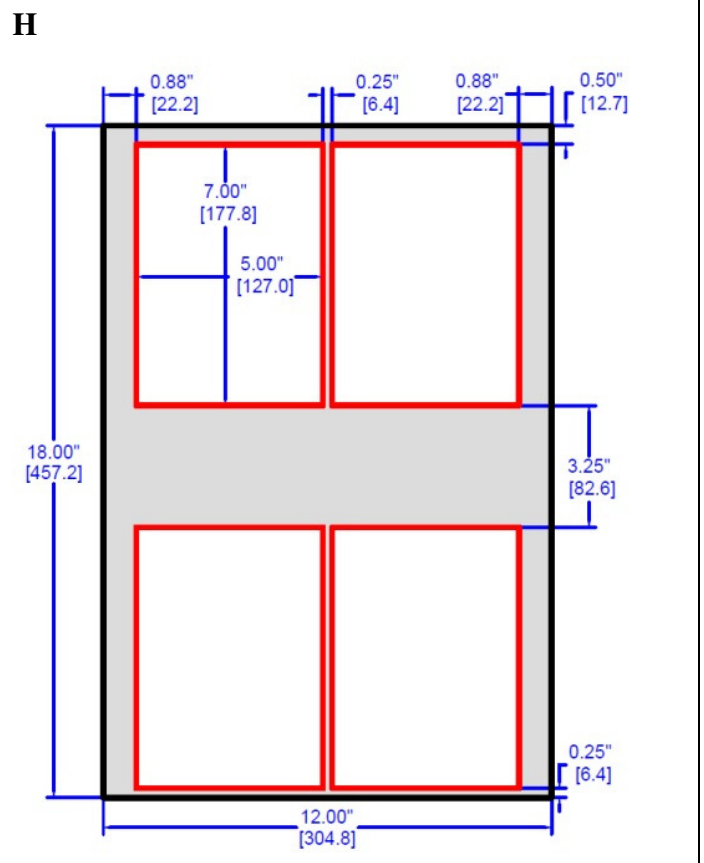
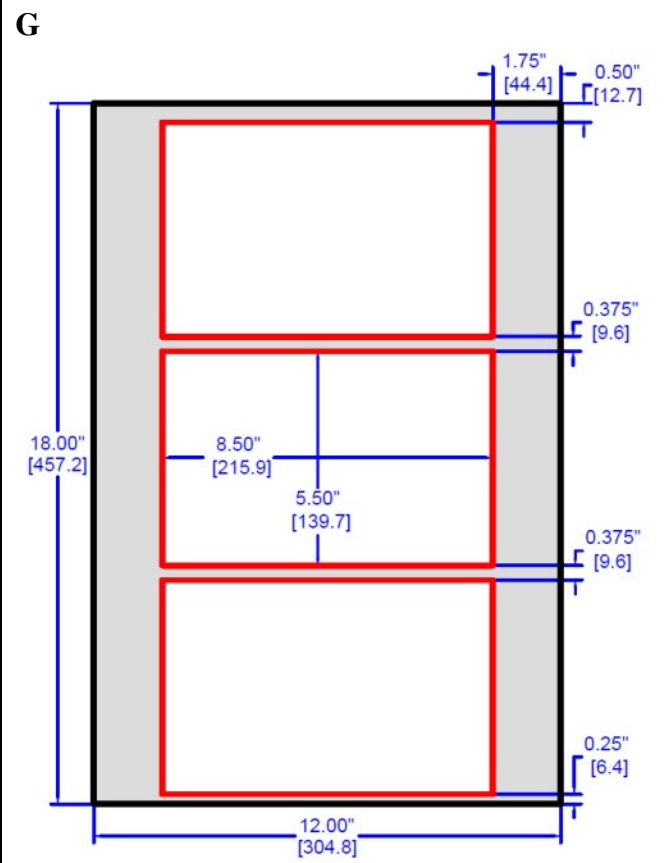
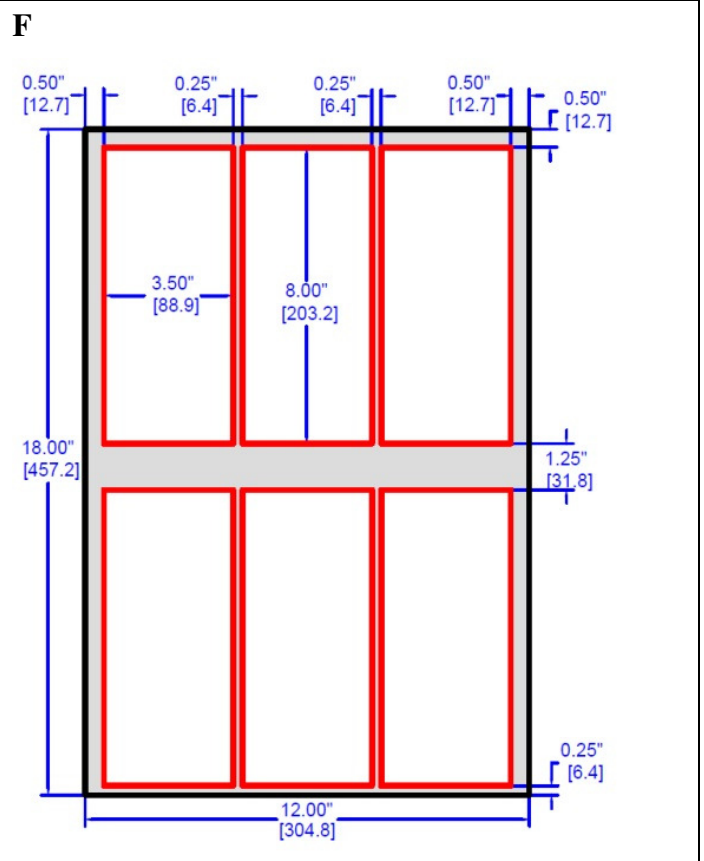
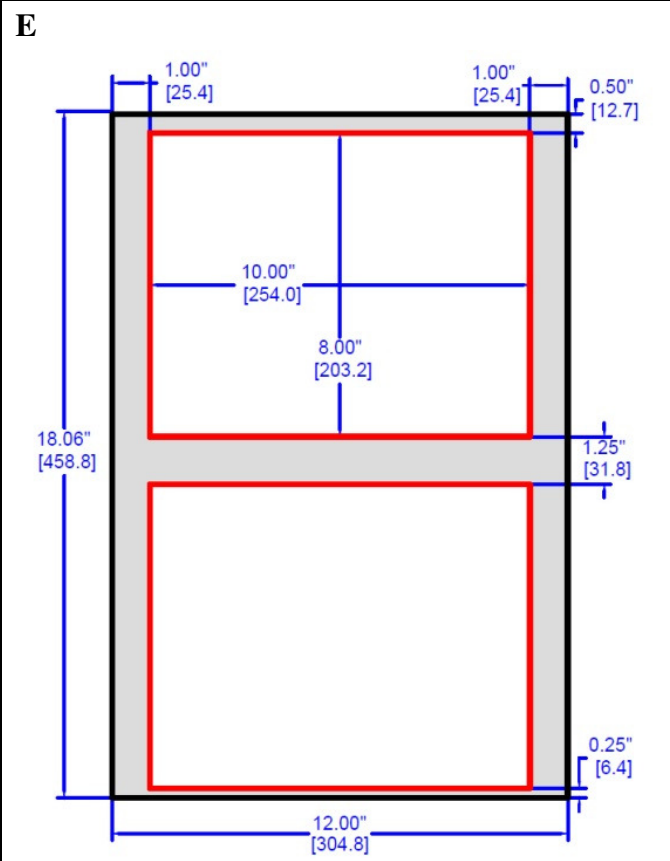

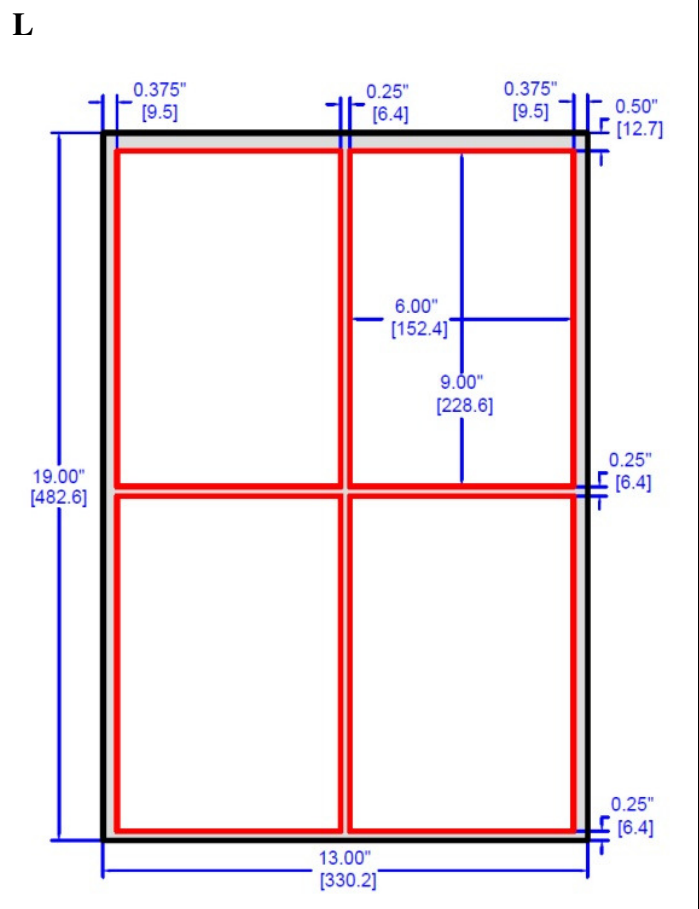
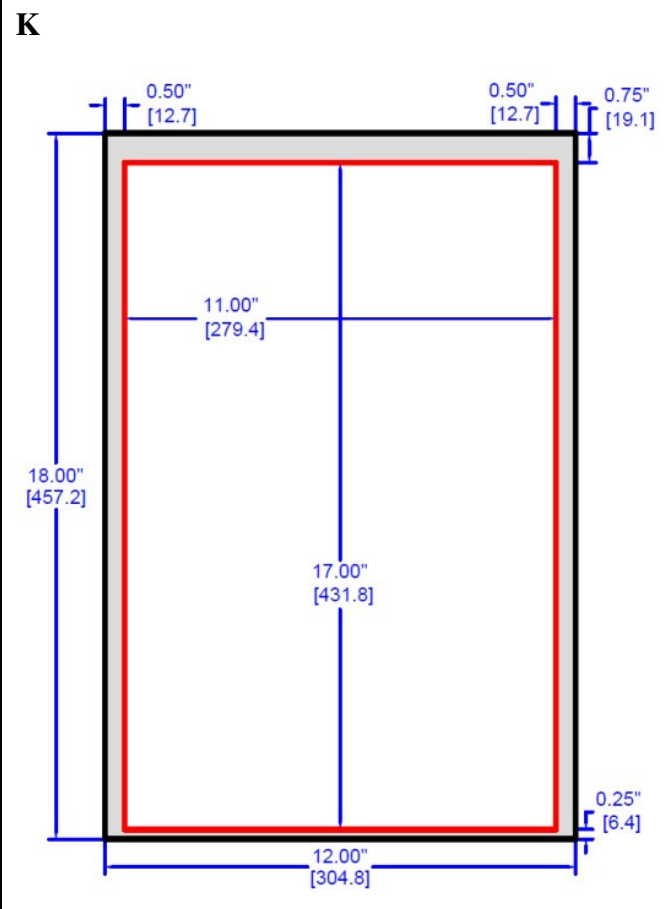
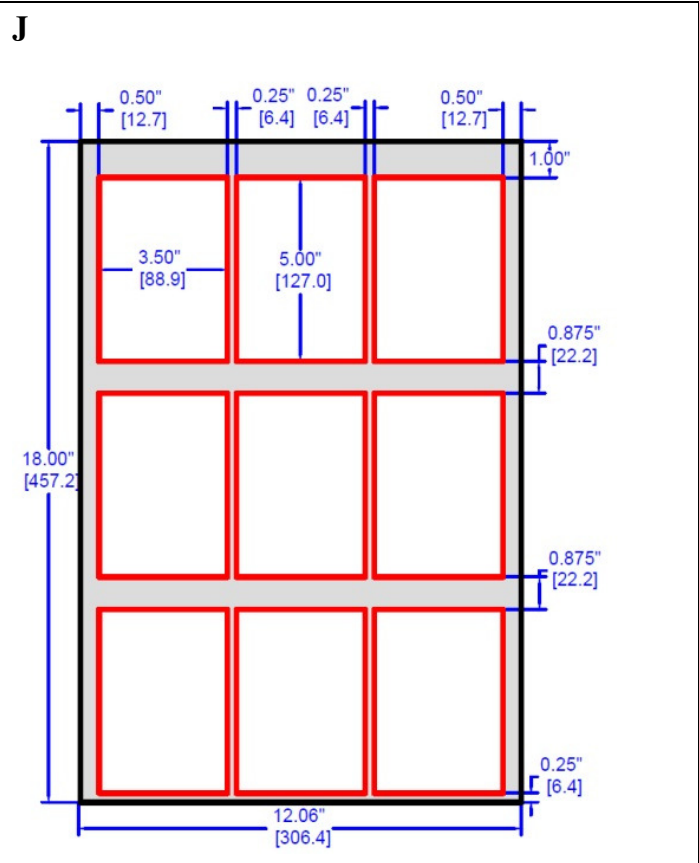
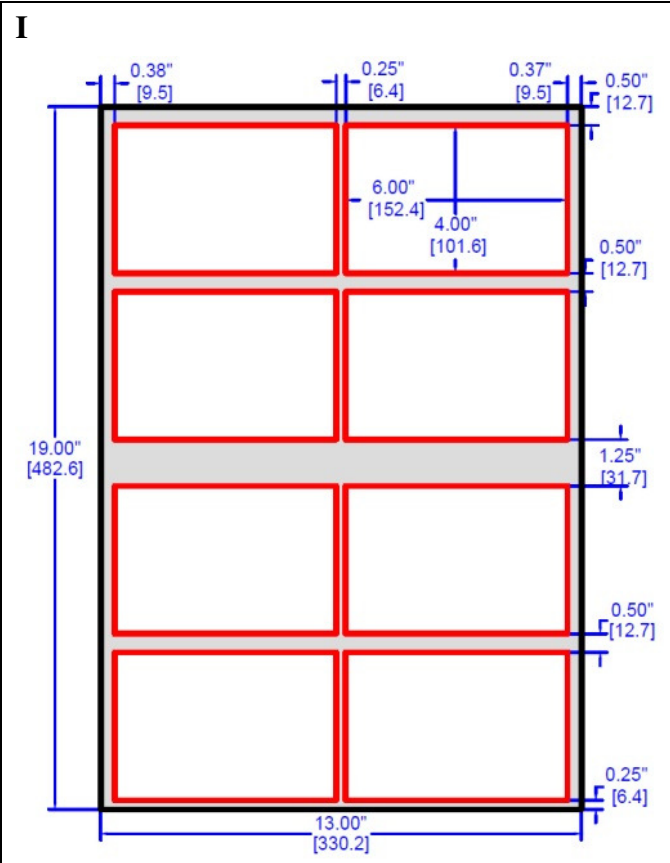

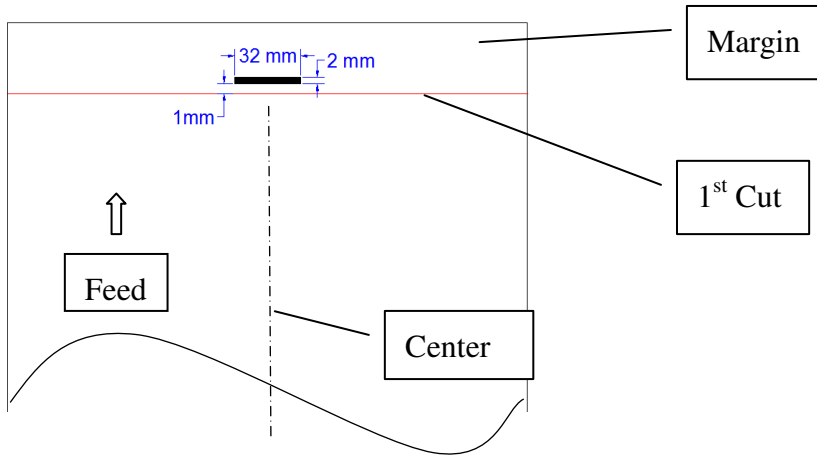

REGISTRATION MARK POSITION

Registration mark will compensate for print shifting. See below for registration mark position.







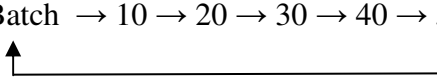

SELECTING A JOB

	Actions	Display Example
1	Turn on the power. Previous job will appear.	#01 BUSINESS CARD NM 2"x3.5" W/G 23
2	Press JOB until the desire job is displayed. 01 → 02 → 03 → 04 ... 13 ↑	#04 PHOTO NM 8"x10 W/G 23
3	Press ENTER to select job	#04 PHOTO NM 8"x10 W/G 23
4	Press  to start operation.	#04 PHOTO NM 8"x10 W/G 23





BATCH COUNT FUNCTION







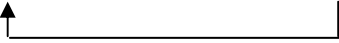
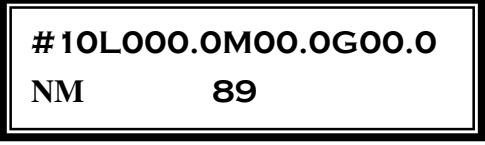

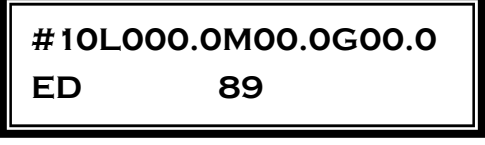

Batch count function is use to automatically stop the machine after a set count of paper has been fed.

	Actions	Display Example
1	Press  until the desire batch count number appears. The batch count will increment by 10 every time the button is pressed. Set "OFF" r no batch count. Batch → 10 → 20 → 30 → 40 → 50 	
2	Press  to select batch count.	
3	Press  to start operation.	



USER DEFINE JOB

Only job#8 – 13 can be program.

	Actions	Display Examples
1	Turn on the power. Previous job will appear.	
2	Press  until the desire job is display. 01 → 02 → 03 → 04 ... 13 	
3	Press  to select job.	



4	Hold  for 4 seconds. “Edit” will appear indicating machine in “Program Mode”.	# 10L000.0M00.0G00.0 ED 89
5	Hold  and press  to increment or  to decrement change finished length in mm.	# 10L 127.0M00.0G00.0 ED 89
6	Hold  and press  to increment or  to decrement change top margin in mm	# 10L 127.0M 12.7G00.0 ED 89
7	Hold  and press  to increment or  to decrement change gutter length in mm	# 10L 127.0M 12.7G06.0 ED 89
8	Press  to save settings.	# 10L 127.0M 12.7G06.0 NM 89

TURBO AND NORMAL MODE

1. Hold  for 4 seconds.
2. Press  to select “Normal Mode” or “Turbo Mode (Default)”.
3. Press  to save settings.

PAPER WEIGHT

Adjust paper weight settings if paper is skewing or miss-feed. Set 1 or 2 for lighter paper and 4 or 5 for heavier paper.

1. Hold  for 4 seconds.
2. Press  to select settings 1-5. Use table below for references.
3. Press  to save settings.



Setting	Paper Weight
1, 2	120 – 210 (gsm)
3	211 – 300 (gsm)
4, 5	301 – 350 (gsm) (Normal Mode)

RESET COUNTER

Hold  and  simultaneously to reset counter to 0.

CLEAR JAM

Incase jam occurs in the machine follow these steps to clear jam.

1. Press  and pull out jam paper toward feeding tray.
2. Press  to move the jam piece toward the exit.
3. If necessary, depending on location of jam occurs, open the corresponding cover or covers.
If jam persists, refer to “**Error Message and Trouble Shooting**”.
4. After clearing the jams, press  to clear all errors.

TROUBLESHOOTING

Error	Troubleshooting
Out of paper	Feed tray empty
miss feed	1. Adjust the feed tray tension 2. Side guide too tight. Adjust side guide. 3. Fan the paper and re load the paper into hopper
jam sensor 2	1. Remove the paper jam by pulling toward stacking tray. 2. Adjust the feed hopper tension, if double feed happens
jam sensor 3	1. Use JOG key to clear the jam 2. Adjust feed hopper tension, if double feed happens
check top cover	Put the top cover in position
check rear cover	Put the rear cover in position
Finish card not clean and neat	Call for service
Error message cannot reset	Check covers and paper jam

OPTIONAL SLITTER CASSETTE

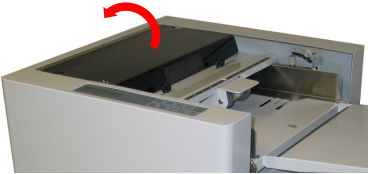
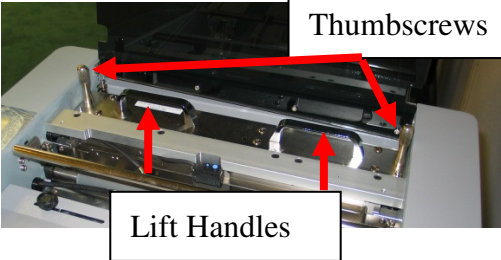

Optional slitters enable the CC-330 to have more range of applications. Follow the step below the replace optional slitter cassette.



1. Lift Top Cover	
2. Remove thumbscrew by turning counter-clockwise on both side of the slitter cassette.	
3. Using both hands, lift the slitter cassette.	
4. Replace with the desired slitter cassette.	
5. Secure the slitter cassette with the thumbscrew by turning them clockwise.	

OPTIONAL CONVEYOR

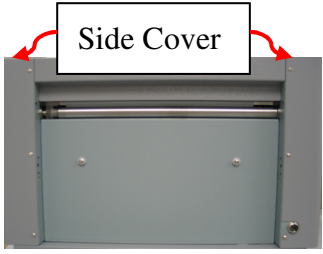
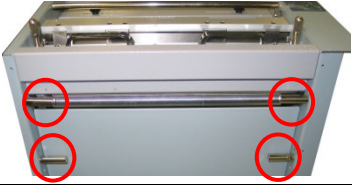
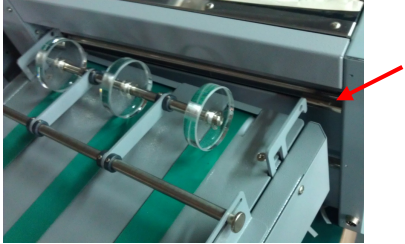
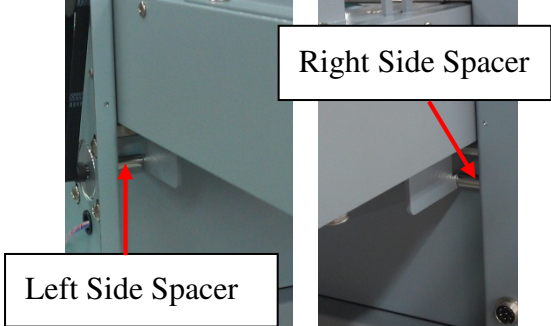
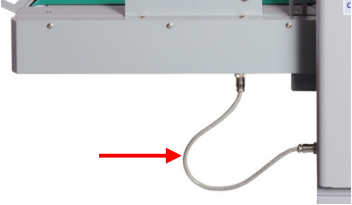
Items List

		
1 x Conveyor	1 x Ramp	1 x Stacking Rollers Assembly
		
1 x Interface Cable	1 x Stand Support	4 x Studs
		
4 x Socket Cap Screws (M6x12)	6 x Lock Washers (M6)	4 X Shoulder Washers
		
4 x Machine Screws (M4 x 12)	2 x Spacer	2 x Machine Screws (M5 x 35)
		
2 X Hex Bolt (M6 x 30)	4 x Washers (M6)	2 X Hex Nuts (M6)
		
2 Thumbscrews (M4 x 12)		

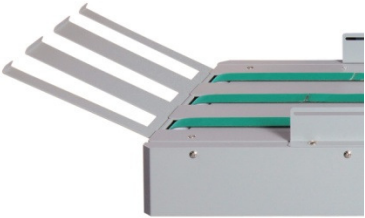
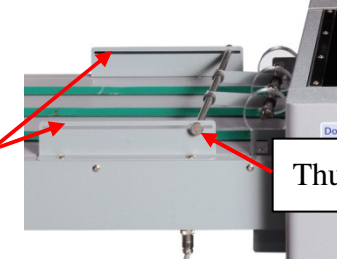
<p>1. Remove the side covers.</p>	
<p>2. Install the 4 studs as shown using Socket 4 Cap Screws (M6x12) and 4 Lock Washers (M6).</p>	
<p>3. Hook the conveyor onto the studs.</p>	
<p>4. Use 2 spacers and Machine Screws (M5 x 35) to secure the conveyor on the left and right side located below the conveyor.</p>	
<p>5. Plug interface cable to conveyor and machine.</p>	
<p>6. Fasten 4 Machine Screws (M4 x 12) and 4 shoulders washers the the end of the conveyor.</p>	

<p>7. Install the ramp using the key holes.</p>	
<p>8. Install Stack Rollers assembly using 2 thumbscrews as shown onto conveyor rails. Adjust roller distance depending on paper finish size for better stacking.</p>	 <div data-bbox="862 527 1037 632" style="border: 1px solid black; padding: 2px; display: inline-block;">Conveyor Rails</div> <div data-bbox="1321 527 1544 590" style="border: 1px solid black; padding: 2px; display: inline-block;">Thumbscrews</div>
<p>9. Install stand support using 2 Hex Bolt (M6 x 30), 4 washers (M6), 2 Lock Washer (M6) and 2 Nuts (M6) and secure stand support to the stand.</p>	
<p>10. Install stand support using 5 x (M5 x 10) screw and washer to secure stand support to the conveyor</p>	

Duplo USA Corporation
3050 S. Daimler St, Santa Ana, CA 92705
www.duplousa.com